



Design Patent Case Law Review: Federal Circuit

By: Michael T. Piery, QUARLES & BRADY LLP



Federal Circuit Cases

1. *Curver Luxembourg, SARL v. Home Expressions Inc.* – the effect of claim language
2. *Campbell Soup Co. v. Gamon Plus, Inc.* – the primary reference requirement
3. *Columbia Sports Wear North America, Inc. v. Seirus Innovative Accessories, Inc.* – the effect of logos in the infringement analysis

Curver Luxembourg, SARL v. Home Expressions Inc.

- 938 F.3d 1334
- Decided: September 12, 2019
- Judges Chen, Hughes, and Stoll

(12) United States Design Patent (10) Patent No.: **US D677,946 S**
Duvigneau (45) Date of Patent: **Mar. 19, 2013**

(54) **PATTERN FOR A CHAIR** D648,544 S * 11/2011 Diverdi et al. D547
8,141,595 B2 * 3/2012 Quigley 139,383 A
(75) Inventor: **Nikolai Duvigneau, Zichron Yaacov (IL)** 2010/0276980 A1 * 11/2010 Tseng 297,452.64

(73) Assignee: **Curver Luxembourg SARL, Neidrecoem (LU)** CN 2566701 Y 8/2003
DE 1,954,564 A1 5/1970
EP 0,796,577 A1 9/1997
EP 701461-0009 5/2007
EP 701461-0010 5/2007
GB 2,257,352 A 1/1993
WO 03/067727 A1 9/2002

(**) Term: **14 Years**

(21) Appl. No.: **29/389,254**

(22) Filed: **Apr. 8, 2011**

(30) **Foreign Application Priority Data**
Oct. 18, 2010 (IL) 50171

(51) **LOC (9) CL** **06-01**

(52) **U.S. Cl.** **D6500**

(58) **Field of Classification Search** D6500-502,
D6587, 595-598, 613, 616-619, 603-606,
D547-54, 1-3, 23, 29, 11-12, 19, 56; 428/17-18,
428/151, 154, 156, 171, 187, 198-199, 542.2,
428/542.6
See application file for complete search history.

(56) **References Cited**

U.S. PATENT DOCUMENTS
1,637,410 A * 8/1927 Coryell 52/446
2,977,265 A * 3/1961 Forsberg et al. 428/116
3,059,668 A 10/1962 Groesman
4,231,434 A 11/1980 Tejo-Gonzalez
D360,531 S * 7/1995 Griffith D5/1
5,340,958 A 8/1996 Ryznaris
5,985,188 A 11/1999 Jennings et al.
6,161,353 A * 12/2000 Negola et al. 52/433
D476,161 S * 6/2003 Sabony et al. D5/47
D478,217 S * 8/2003 Brenner et al. D5/47
D556,478 S * 12/2007 Bryant et al. D6-500
D580,263 S * 3/2009 Wang D5/47
D613,072 S * 4/2010 Rallery et al. D5/47
D623,216 S * 9/2010 Moore D25/138
D646,008 S * 10/2011 Bogdan et al. D6-569

FOREIGN PATENT DOCUMENTS

OTHER PUBLICATIONS
The International Search Report for International Application No. PCT/IL2009/000369, completed on Aug. 20, 2009, mailed on Oct. 28, 2009, three pages total.
The Office Action issued Oct. 20, 2010, concerning European Application No. 09 754 322.7, five pages total.
Tokuin Toshiko: "AMI AMI chair" Milan Design Week 2008 Preview, [Poland] Apr. 10, 2008 (Apr. 10, 2008), XP002542166 Retrieved from the Internet: URL <http://www.dczain.net/thread/12198/> [retrieved on Aug. 21, 2009].

(Continued)

Primary Examiner — Kelley Donnelly
(74) **Attorney, Agent, or Firm** — Nath, Goldberg & Meyer, Jerald L. Meyer

(57) **CLAIM**
The ornamental design for a pattern for a chair, as shown and described.

DESCRIPTION
FIG. 1 is a front view of a design for a pattern for a chair;
FIG. 2 is a top view of a design for a pattern for a chair;
FIG. 3 is a bottom view of a design for a pattern for a chair;
FIG. 4 is a perspective view of a design for a pattern for a chair; and,
FIG. 5 is an enlarged view from the perspective view a rattan design for a pattern for a chair.

1 Claim, 5 Drawing Sheets

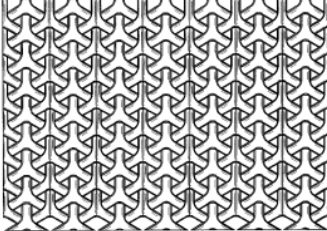

Curver Luxembourg, SARL v. Home Expressions Inc.

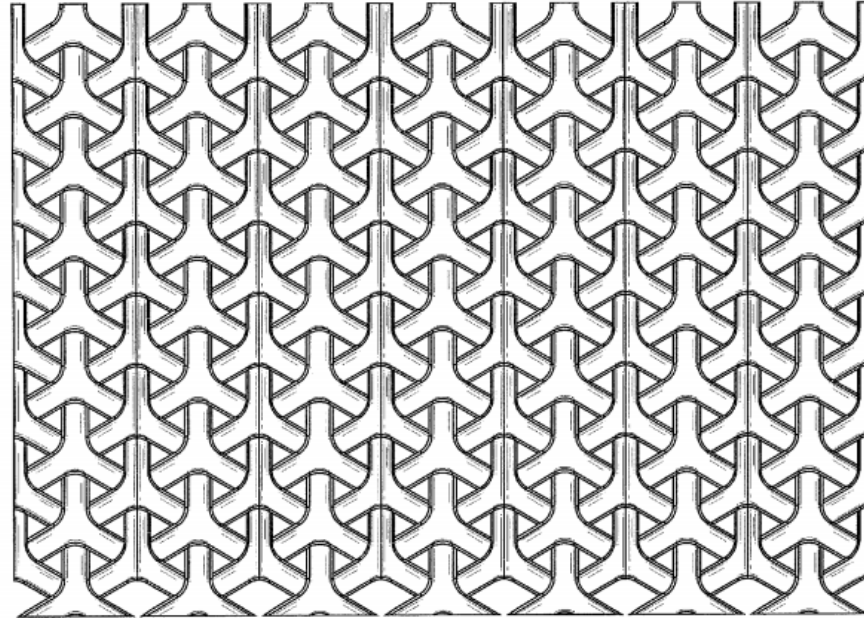
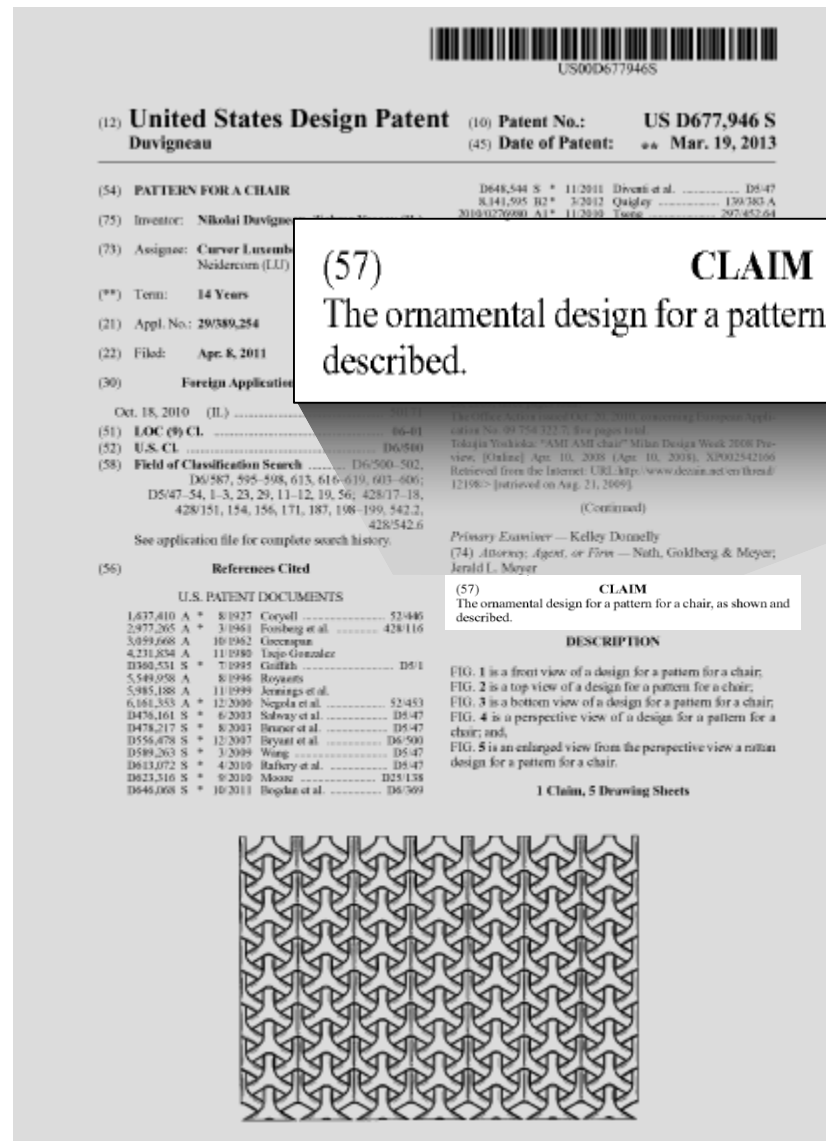

FIG. 1



FIG. 2

Curver Luxembourg, SARL v. Home Expressions Inc.



Curver Luxembourg, SARL v. Home Expressions Inc.

PROCEDURAL HISTORY

- Curver Luxembourg sued Home Expressions in the District of New Jersey
- D.N.J. granted Home Expressions' motion to dismiss and denied Curver's motion for reconsideration



Curver Luxembourg, SARL v. Home Expressions Inc.

FEDERAL CIRCUIT: AFFIRMED

“Because we agree with the district court that the claim language ‘ornamental design for a pattern for a chair’ limits the scope of the claimed design in this case, we affirm.”



Curver Luxembourg, SARL v. Home Expressions Inc.

FEDERAL CIRCUIT REASONING: PRECEDENT

- “And the thing invented or produced, for which a patent is given, is that which gives a peculiar or distinctive appearance to the manufacture, or article to which it may be applied, or to which it gives form.”
 - Gorham Mfg. Co. v. White, 81 U.S. 511, 524 (1871)
- “[I]t is the application of the design to an article of manufacture that Congress wishes to promote, and an applicant has not reduced his invention to practice and has been of little help to the art if he does not teach the manner of applying his design.”
 - In re Schnell, 46 F.2d 203, 209 (C.C.P.A. 1931)

Curver Luxembourg, SARL v. Home Expressions Inc.

FEDERAL CIRCUIT REASONING: USPTO PRACTICE

- 37 C.F.R. § 1.153
- MPEP § 1502

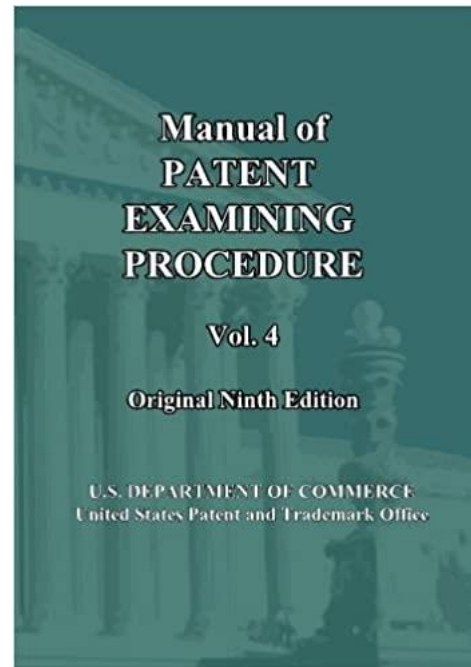
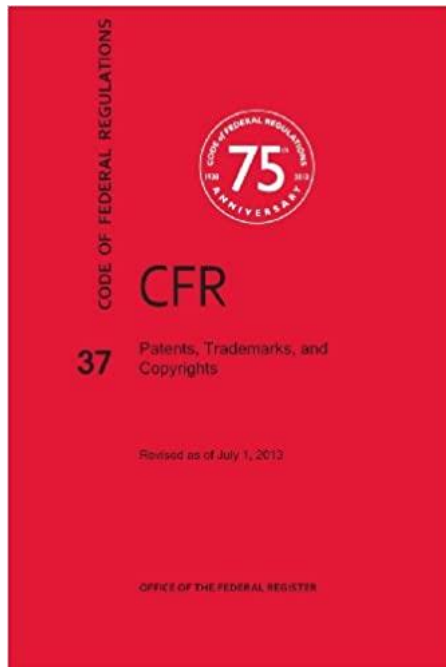

Curver Luxembourg, SARL v. Home Expressions Inc.

FEDERAL CIRCUIT REASONING: PROSECUTION HISTORY ESTOPPEL

Amendments to the Specification:

Please amend the specification as follows:

~~FURNITURE (PART OF)~~ PATTERN FOR A CHAIR

I CLAIM:

The ornamental design for a pattern for a chair ~~rattan design for a furniture part~~, as shown and described.

Curver Luxembourg, SARL v. Home Expressions Inc.

FEDERAL CIRCUIT REASONING: IN RE GLAVAS

- Statements about anticipation were dicta.
- Here, there is no dispute that a basket embodying a particular ornamental pattern is not substantially similar in appearance to a chair embodying that same pattern such that the former would infringe a design patent covering the latter.
- *Egyptian Goddess* overruled *In re Glavas* to the extent it is inconsistent.

Campbell Soup Co. v. Gamon Plus, Inc.

- 939 F.3d 1335
- Decided: September 26, 2019
- Judges Moore and Prost; dissent by Judge Newman

US00D6216455

(12) **United States Design Patent**
Johnson et al.

(10) Patent No.: **US D621,645 S**
(45) Date of Patent: **Aug. 17, 2010**

(54) **GRAVITY FEED DISPENSER DISPLAY**

(75) Inventors: **Terry J. Johnson**, Chicago, IL (US);
John Schoemer, Elk Grove Village, IL (US);
Travis O. Johnson, Chicago, IL (US)

(73) Assignee: **Gamon Plus, Inc.**, Elk Grove, IL (US)

(*) Term: **14 Years**

(21) Appl. No.: **29/355,536**

(22) Filed: **Feb. 9, 2010**

Related U.S. Application Data

(69) Continuation of application No. 29/344,245, filed on Sep. 25, 2009, now Pat. No. Des. 612,646, which is a continuation of application No. 29/330,839, filed on Jun. 29, 2009, now Pat. No. Des. 608,575, which is a continuation of application No. 29/332,015, filed on Feb. 6, 2009, now Pat. No. Des. 595,974, which is a division of application No. 29/318,303, filed on May 16, 2008, now Pat. No. Des. 588,386, which is a continuation of application No. 11/164,784, filed on Dec. 6, 2005, which is a continuation-in-part of application No. 11/255,271, filed on Oct. 21, 2005, now abandoned, which is a division of application No. 10/900,387, filed on Jun. 20, 2005, now Pat. No. 6,991,116.

(Continued)

OTHER PUBLICATIONS

POP & Siga Design regarding Wdka's Juice Makers, Mar./Apr. 1997, p. 61.

(Continued)

Primary Examiner—Brian N Vinson
(74) Attorney, Agent, or Firm—SAIDMAN DesignLaw Group

CLAIM

(57) The ornamental design for a gravity feed dispenser display, as shown and described.

DESCRIPTION

The sole FIGURE is a perspective view of a gravity feed dispenser display showing our new design. The broken line showing is for the purpose of illustrating portions of the gravity feed dispenser display and forms no part of the claimed design.

References Cited

U.S. PATENT DOCUMENTS

1,684,897 A 12/1928 Washbon
1,999,021 A 4/1935 Marsh
2,352,191 A 8/1948 Weichenthal

1 Claim, 1 Drawing Sheet

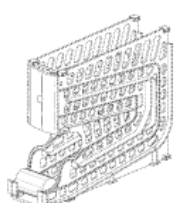

US00D612646S

(12) **United States Design Patent**
Johnson et al.

(10) Patent No.: **US D612,646 S**
(45) Date of Patent: **Mar. 30, 2010**

(54) **GRAVITY FEED DISPENSER DISPLAY**

(75) Inventors: **Terry J. Johnson**, Chicago, IL (US);
John Schoemer, Elk Grove Village, IL (US);
Travis O. Johnson, Chicago, IL (US)

(73) Assignee: **Gamon Plus, Inc.**, Elk Grove, IL (US)

(*) Term: **14 Years**

(21) Appl. No.: **29/344,245**

(22) Filed: **Sep. 25, 2009**

Related U.S. Application Data

(69) Continuation of application No. 29/339,359, filed on Jun. 25, 2009, which is a continuation of application No. 29/332,015, filed on Feb. 6, 2009, now Pat. No. Des. 595,974, which is a division of application No. 29/318,303, filed on May 16, 2008, now Pat. No. Des. 588,386, which is a continuation of application No. 11/164,784, filed on Dec. 6, 2005, which is a continuation-in-part of application No. 11/255,271, filed on Oct. 21, 2005, now abandoned, which is a division of application No. 10/900,387, filed on Jun. 20, 2005, now Pat. No. 6,991,116.

(Continued)

OTHER PUBLICATIONS

POP & Siga Design regarding Wdka's Juice Makers, Mar./Apr. 1997, p. 61.

(Continued)

Primary Examiner—Brian N Vinson
(74) Attorney, Agent, or Firm—SAIDMAN DesignLaw Group

CLAIM

(57) The ornamental design for a gravity feed dispenser display, as shown and described.

DESCRIPTION

The sole FIGURE is a perspective view of a gravity feed dispenser display showing our new design. The broken line disclosure in the views is understood to represent the article in which the claimed design is embodied, but which forms no part of the claimed design, and where a broken line shows a claimed surface it is understood to form an unclaimed boundary between claimed and unclaimed surfaces.

References Cited

U.S. PATENT DOCUMENTS

2,352,191 A 8/1948 Weichenthal
2,443,871 A 6/1948 Shield
2,452,527 A 9/1948 Mison
2,488,145 A 5/1959 Knott et al.
2,996,546 A 8/1961 Gorman et al.

1 Claim, 1 Drawing Sheet

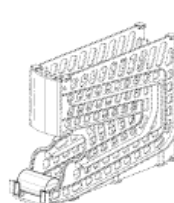

Campbell Soup Co. v. Gamon Plus, Inc.

- Annotated claims

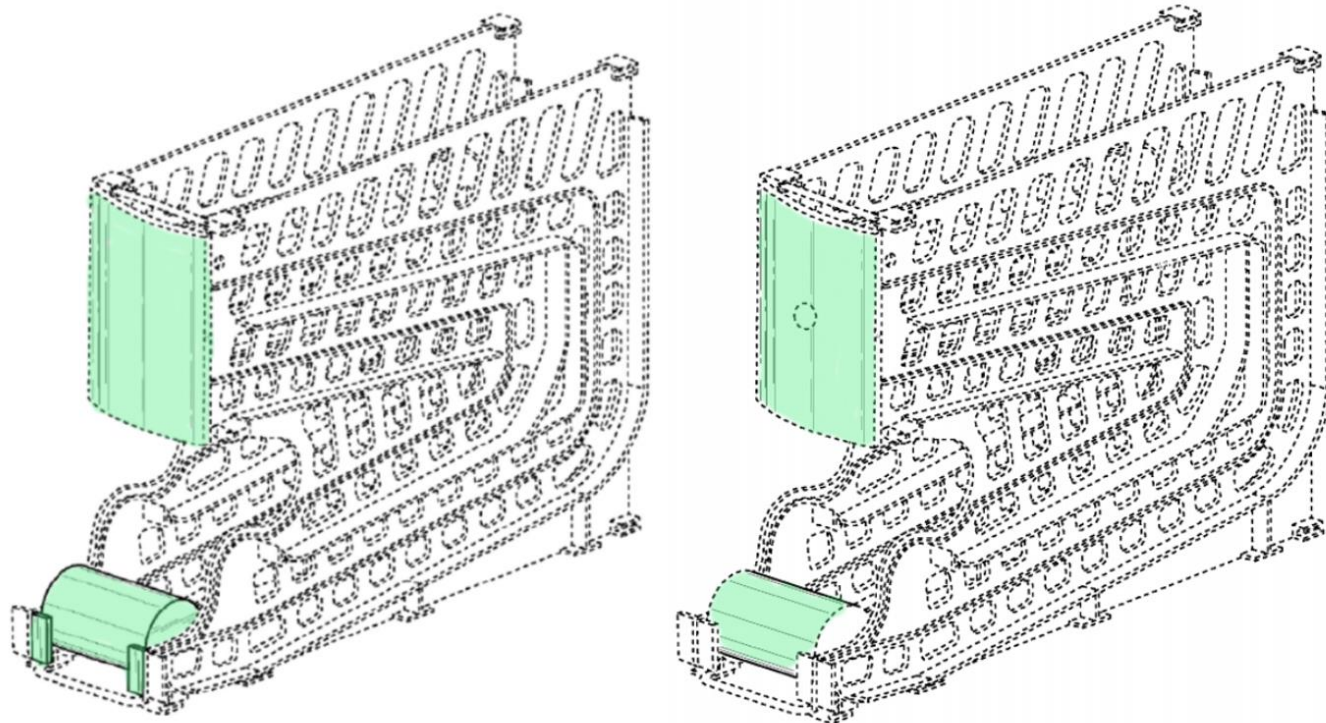

Campbell Soup Co. v. Gamon Plus, Inc.

PROCEDURAL HISTORY

- IPR2017-00091, IPR2017-00094
- P.T.A.B. Final Written Decisions: Not obvious



Campbell Soup Co. v. Gamon Plus, Inc.

FEDERAL CIRCUIT: AFFIRMED-IN-PART, VACATED-IN-PART, AND REMANDED

“Because substantial evidence does not support the Board’s finding that Linz is not a proper primary reference, and substantial evidence supports the Board’s finding that Samways is not a proper primary reference, we affirm-in-part, vacate-in-part, and remand.”



Campbell Soup Co. v. Gamon Plus, Inc.

IS LINZ A PROPER ROSEN REFERENCE?

- Linz - D405,622
- Ornamental design for a display rack

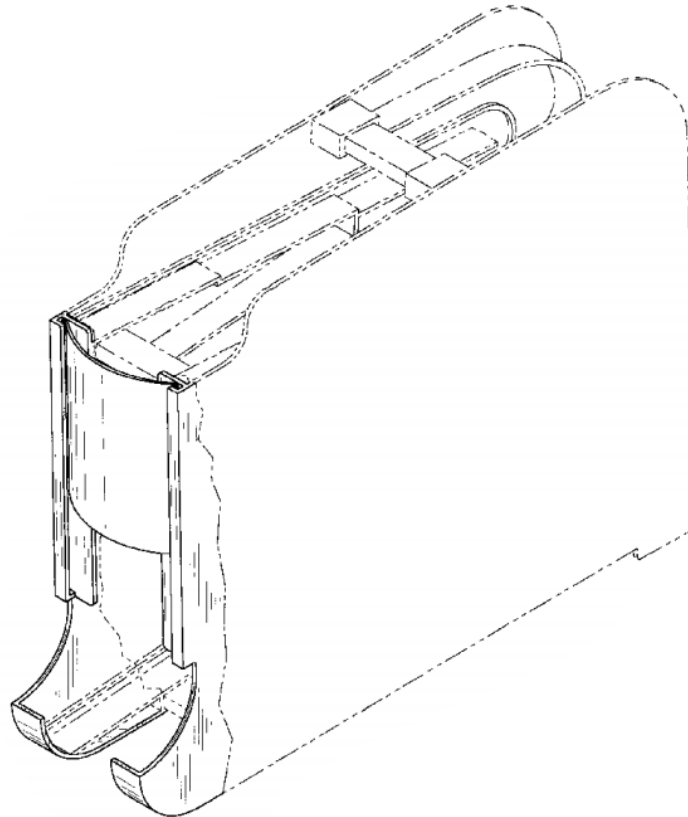

Campbell Soup Co. v. Gamon Plus, Inc.

IS LINZ A PROPER ROSEN REFERENCE?

- P.T.A.B. – NO
- No cylindrical object in the display area
- Hypothetical can is not “in existence” under *Durling*

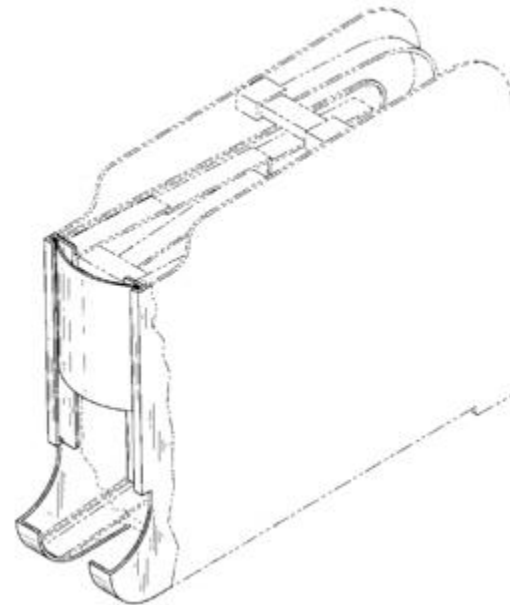
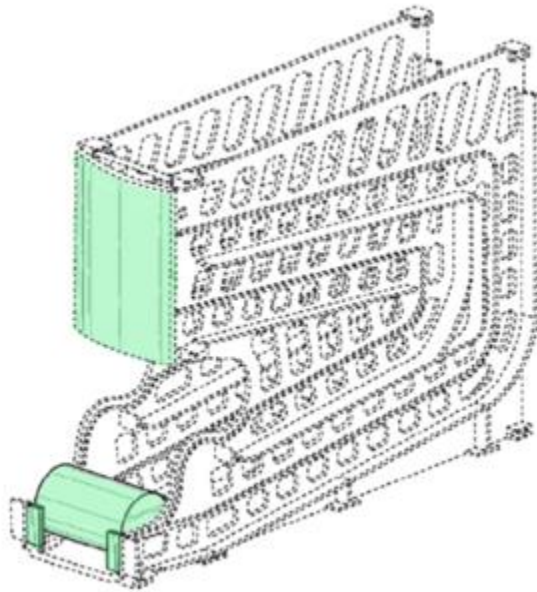

Campbell Soup Co. v. Gamon Plus, Inc.

IS LINZ A PROPER ROSEN REFERENCE?

- Federal Circuit – YES
- Undisputed that Linz is for dispensing cans and a can would be used in the system
- Can's dimensional differences are insufficient

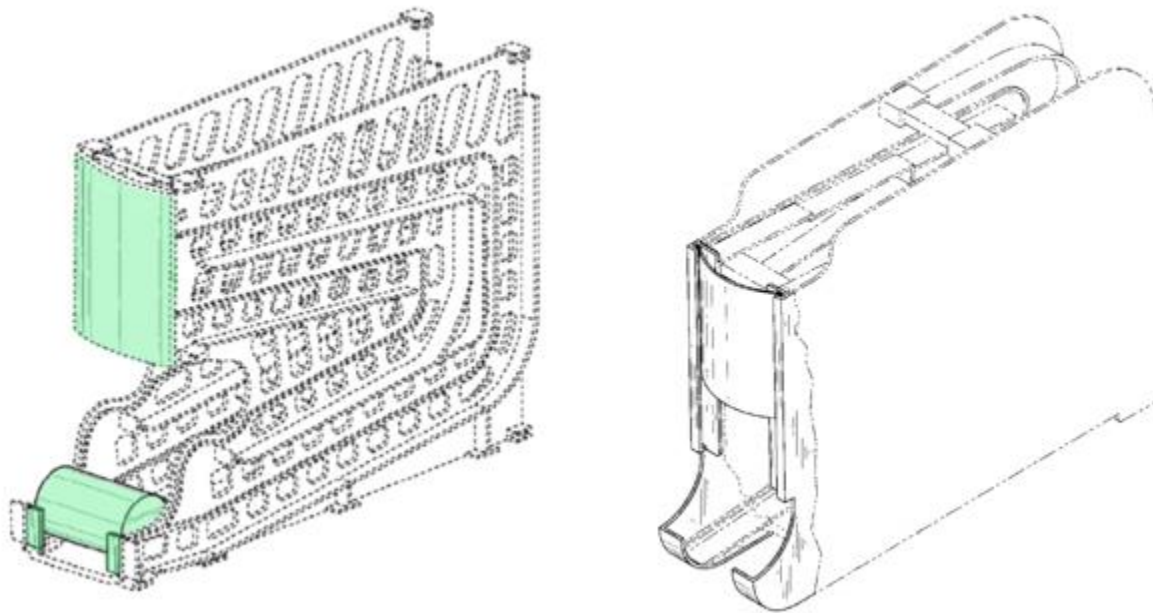

Campbell Soup Co. v. Gamon Plus, Inc.

Judge Newman, Dissenting

- Linz is not a proper *Rosen* reference
- Absence of a major design component cannot be insubstantial
- Not in existence, but a potential design based on how utilitarian features like curved could display a can

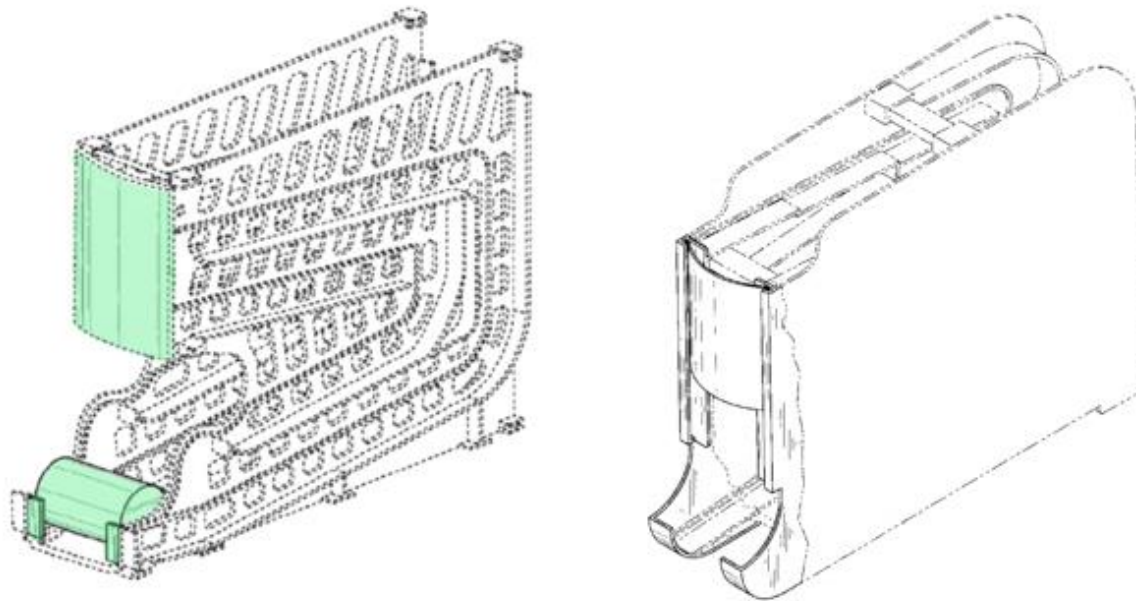

Campbell Soup Co. v. Gamon Plus, Inc.

IS SAMWAYS A PROPER ROSEN REFERENCE?

- P.T.A.B. and Federal Circuit – NO
- Dual dispensing area
- Different front label area

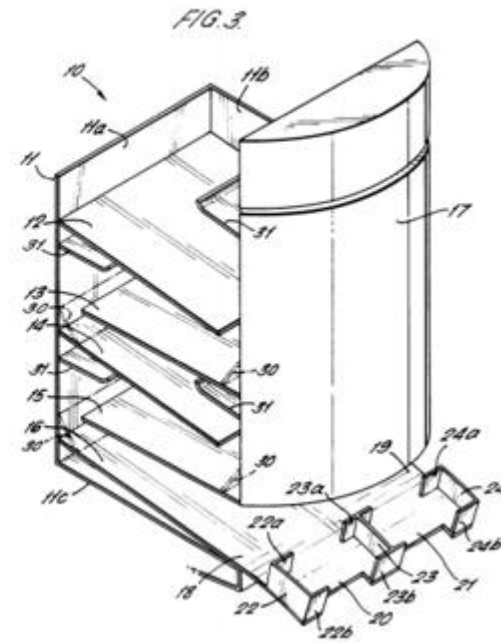
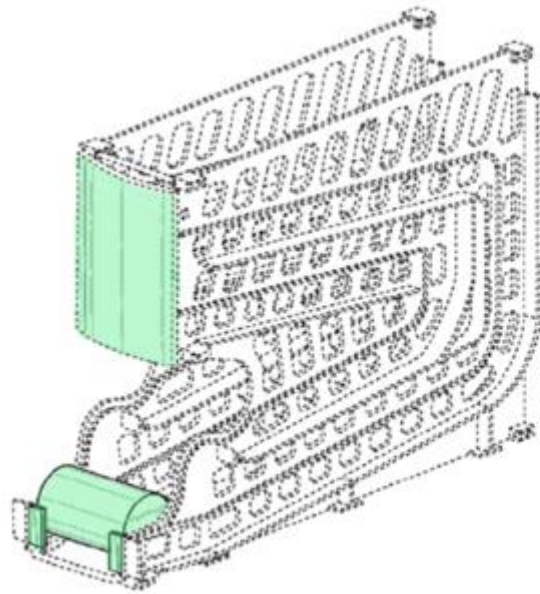

Columbia Sportswear v. Seirus Innovative Accessories

- 942 F.3d 1119
- Judges Lourie, Moore, and Stoll
- Decided: November 13, 2019
- Reh’g denied: March 5, 2020

(12) **United States Design Patent** (10) Patent No.: **US D657,093 S**
Snyder (45) Date of Patent: **** Apr. 3, 2012**

(54) **HEAT REFLECTIVE MATERIAL.** *Primary Examiner — Susan Bennett Hattan*
 (75) Inventor: **Zach Snyder**, Portland, OR (US) *Assistant Examiner — Barbara B Lohr*
 (73) Assignee: **Columbia Sportswear North America, Inc.**, Portland, OR (US) *(74) Attorney, Agent, or Firm — Schwabe, Williamson & Wyatt, P.C.*

(**) Term: **14 Years**
 (21) Appl. No.: **29/346,786**

(22) Filed: **Nov. 5, 2009**

(51) **LOC (9) CL.** **29-03**
 (52) **U.S. CL.** **D29/101.1**

(58) **Field of Classification Search** D5:47,
 D5:54, 55, 56, 57, D6:582, D32:40, 442:327,
 442:394; D29/100, 101.2, 101.3, 101.4,
 D29/101.5; 428/196, 131; 451/523, 533,
 451/537, 539; D8/90
 See application file for complete search history.

(56) **References Cited**

U.S. PATENT DOCUMENTS

D119,351 S *	3/1940	Tabin	D5:56
D130,877 S *	12/1941	Tips	D5:47
D154,151 S *	6/1949	Ryan	D6:582
7,226,879 B2 *	6/2007	Tilton et al.	442:327
D551,407 S *	9/2007	Caruso et al.	D32:40
D573,354 S *	7/2008	Nam	D5:62
D583,568 S *	12/2008	Sordi	D5:28
D631,262 S *	1/2011	Evans	D5:56
D638,224 S *	5/2011	Ko et al.	D5:56

FOREIGN PATENT DOCUMENTS

JP	63-125525	8/1988
----	-----------	--------

* cited by examiner

CLAIM
 (57) The ornamental design of a heat reflective material, as shown and described.

DESCRIPTION

FIG. 1 is an elevational view of a heat reflective material; FIG. 2 is an enlarged elevational view thereof, taken from any area in the design;
 FIG. 3 is a cross-sectional side elevational view thereof, taken in the direction of line 3-3 in FIG. 1;
 FIG. 4 is a top perspective view of the heat reflective material as used in a sleeping bag;
 FIG. 5 is a front perspective view of the heat reflective material as used in footwear;
 FIG. 6 is a front perspective view of the heat reflective material as used in legwear;
 FIG. 7 is a rear perspective view of the heat reflective material as used in a sock;
 FIG. 8 is a rear perspective view of the heat reflective material as used in handwear;
 FIG. 9 is a front perspective view of the heat reflective material as used in outerwear; and,
 FIG. 10 is a rear perspective view of the heat reflective material as used in footwear.
 The broken lines in the drawings depict environmental subject matter only and form no part of the claimed design.

1 Claim, 3 Drawing Sheets

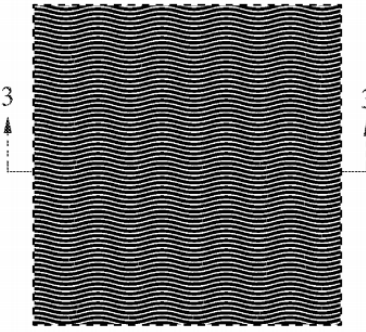

Columbia Sportswear v. Seirus Innovative Accessories

- Claim

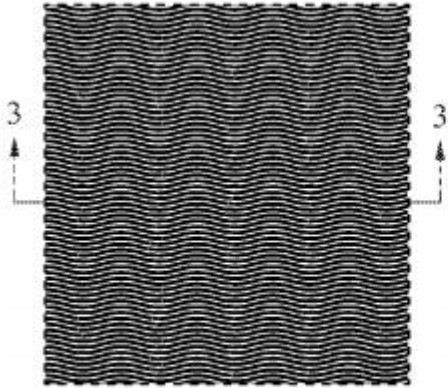

FIG. 1

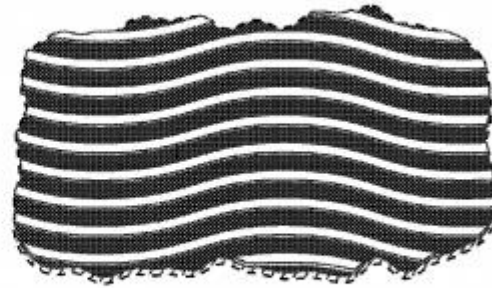

FIG. 2

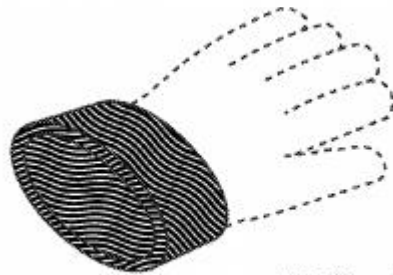

FIG. 8

Columbia Sportswear v. Seirus Innovative Accessories

PROCEDURAL HISTORY

- Columbia Sportswear sued Seirus in the District of Oregon
- District of Oregon granted summary judgment of infringement and transferred action
- Southern District of California awarded damages after trial



Columbia Sportswear v. Seirus Innovative Accessories

FEDERAL CIRCUIT: REVERSED AND REMANDED INFRINGEMENT FINDING

Two reasons for error:

- (1) the court improperly declined to consider the effect of Seirus's logo in its infringement analysis and;
- (2) the court resolved a series of disputed fact issues, in some instances relying on an incorrect standard, that should have been tried to a jury.



Columbia Sportswear v. Seirus Innovative Accessories

THE EFFECT OF SEIRUS'S LOGO

- Fact finder must determine is the “effect of the whole design substantially the same”? *Gorham*, 81 U.S. at 530.
- Inconsistent with *Gorham* to ignore elements entirely, simply because those elements included the name of the defendant.



Columbia Sportswear v. Seirus Innovative Accessories

THE EFFECT OF SEIRUS'S LOGO – DISTINGUISHING L.A. GEAR

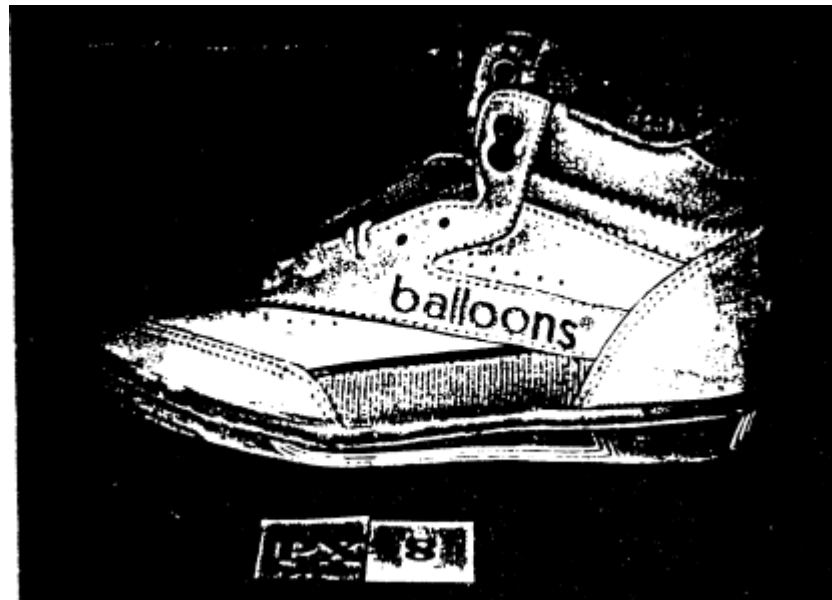
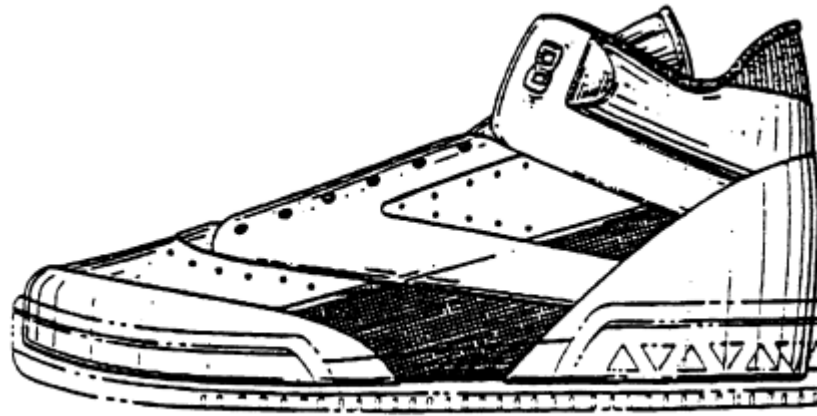

Columbia Sportswear v. Seirus Innovative Accessories

THE EFFECT OF SEIRUS'S LOGO – DISTINGUISHING L.A. GEAR

- “Design patent infringement relates solely to the patented design, and does not require proof of unfair competition in the marketplace or allow of avoidance of infringement by labelling.” 988 F.2d at 1126

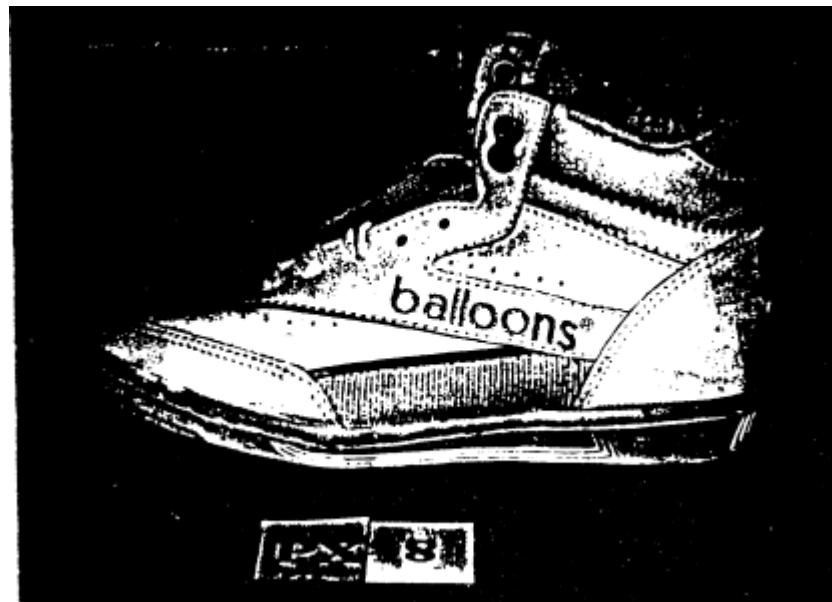

Columbia Sportswear v. Seirus Innovative Accessories

THE EFFECT OF SEIRUS'S LOGO – DISTINGUISHING L.A. GEAR

- Copying was admitted
- Does not prohibit the fact finder from *considering* an ornamental logo as one among other potential differences

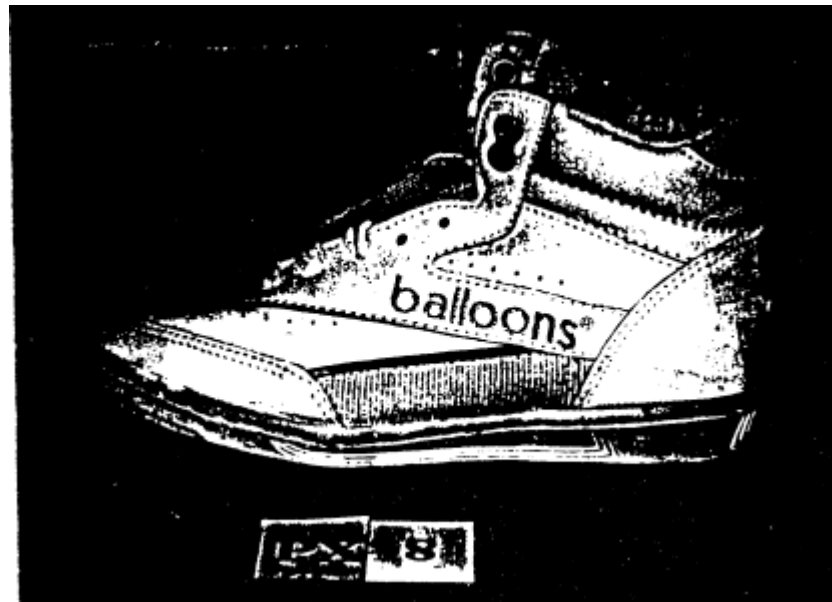

Columbia Sportswear v. Seirus Innovative Accessories

ADDITIONAL DISPUTED FACTS

- Consistent waves v. waves of varying thickness

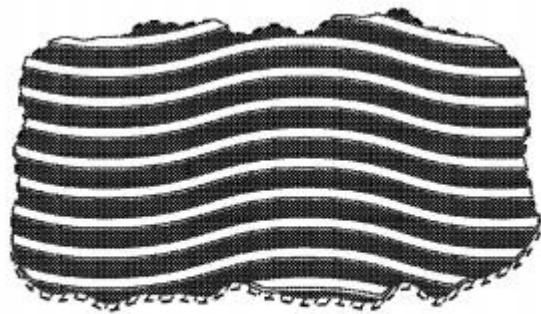

FIG. 2



Columbia Sportswear v. Seirus Innovative Accessories.

ADDITIONAL DISPUTED FACTS

- Visual impression of an ordinary observer

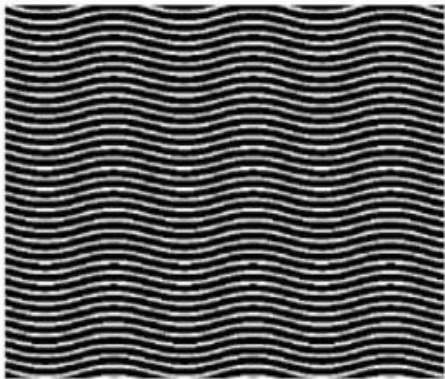

Columbia's D'093 patent

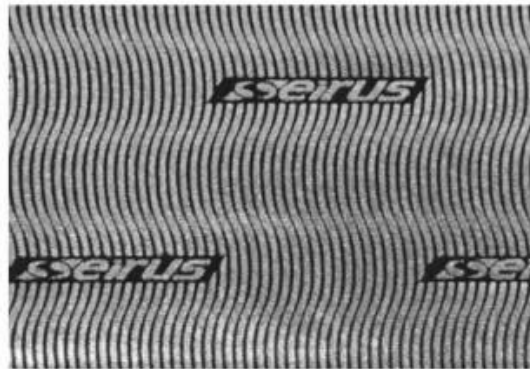

Seirus's HeatWave

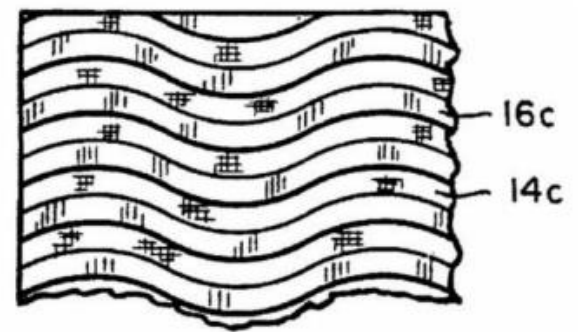

'949 patent

Federal Circuit Cases

COMMENTS



Tracy-Gene Durkin
Director
Sterne Kessler Goldstein & Fox



Christopher Carani
Shareholder
McAndrews, Held & Malloy

THANK YOU