

NOTE: This disposition is nonprecedential.

**United States Court of Appeals  
for the Federal Circuit**

---

**CHOIROCK CONTENTS FACTORY CO., LTD.,**  
*Appellant*

v.

**ALDRIC SAUCIER, SPIN MASTER, LTD.,**  
*Appellees*

---

2019-1335

---

Appeal from the United States Patent and Trademark  
Office, Patent Trial and Appeal Board in No. IPR2017-  
00030.

---

Decided: February 21, 2020

---

HILARY L. PRESTON, Vinson & Elkins LLP, New York,  
NY, argued for appellant. Also represented by SIHO YOO,  
San Francisco, CA.

JENNIFER C. BAILEY, Erise IP, P.A., Overland Park, KS,  
argued for appellees. Also represented by MEGAN JOANNA  
REDMOND.

---

Before DYK, BRYSON, and TARANTO, *Circuit Judges*.

Opinion for the court filed by *Circuit Judge* BRYSON.

Opinion dissenting in part filed by *Circuit Judge* DYK.

BRYSON, *Circuit Judge*.

Choirock Contents Factory Co., Ltd., appeals from the final written decision of the Patent Trial and Appeals Board in an *inter partes* review proceeding. The Board held that Choirock did not prove that claims 1–4 and 7–14 of U.S. Patent No. 7,306,504 (“the ’504 patent”) are unpatentable. We affirm.

I

A

The ’504 patent, which is owned by appellee Spin Master, Ltd., is directed to a transformable toy adapted to open and close to reveal and conceal a figurine. ’504 patent, col. 2, ll. 44–46. Figure 1 illustrates the toy 10 in an open position according to one embodiment:

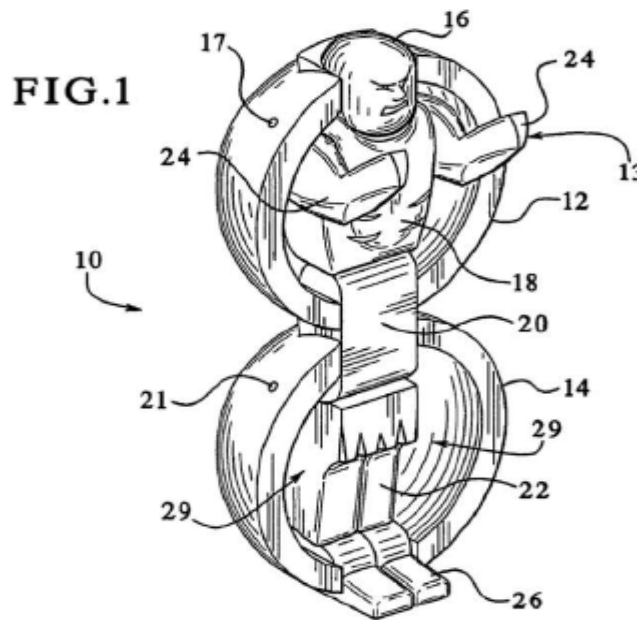

The '504 patent calls the figurine 13 a “display member,” alluding to the fact that the figurine is on display when the toy is in the open position. *Id.* at col. 3, ll. 21–30.

Figure 4 illustrates the embodiment of Figure 1 in which the toy 10 is in a closed position and the figurine or “display member” is hidden:

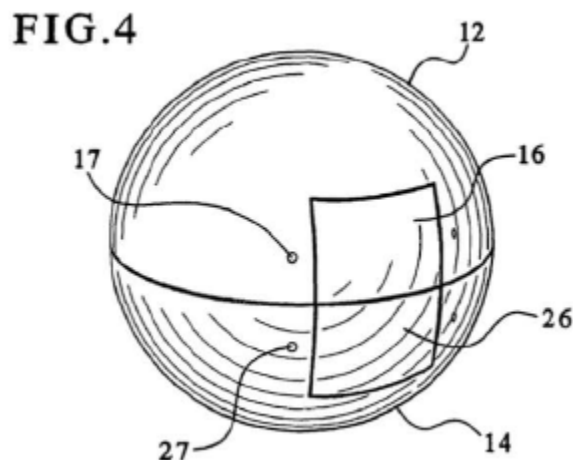

As depicted in Figures 1 and 4 and described in the specification, the display member is connected to the inside surfaces of at least one of the two hemispherical pieces 12 and 14 that form the outer shell of the toy, which is seen when the toy is in the closed position. *Id.* at col. 3, ll. 15–17. Pieces 12 and 14 are movably connected to the opposite ends of a coupler or hinge 20. *Id.* at col. 2, ll. 47–59. The '504 patent refers to pieces 12 and 14 as “movable members.” *Id.* at col. 2:47–51.

Pieces 12 and 14 are not the only parts of the toy that can move. The display member itself (figurine 13) is made up of constituent parts, several of which can move independently of any movement by the movable members 12 and 14. The '504 patent explains:

In this embodiment, the display member **13** is a figure or figurine and includes a first revealer **16**

formed as a head of the figure, a body **18** positioned adjacent to the first reveler **16**, a pair of second revealers **24** in the form of arms movably connected to opposing sides of the body **18**, a coupler **20** connected between the first and second movable members, a support **22** positioned adjacent to the coupler and a third reveler **26** positioned adjacent to the support **22** and movably connected to the second movable member.

*Id.* at col. 3, ll. 21–30. Figure 3 illustrates how some of the constituent pieces of the display member, referred to as the “revealers,” can be moved:

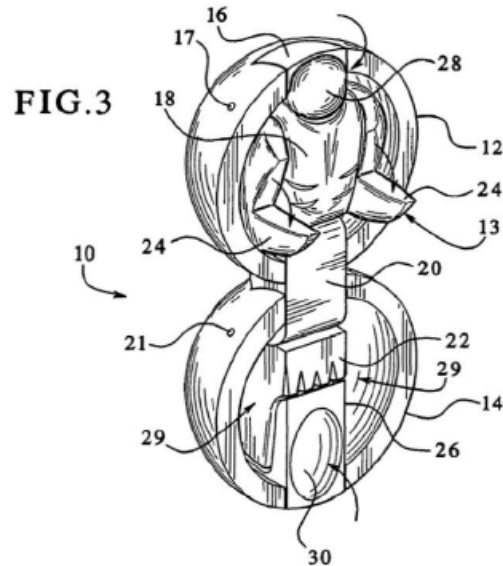

In Figure 3, the head, or first reveler **16**, has rotated around, so that the image of the face is in the “concealed position.” *Id.* at col. 3, line 57, through col. 4, line 6. The arms, or second revealers **24**, have been retracted downward from their extended position shown in Figure 1. *Id.* at col. 4, ll. 18–24. Finally, the third reveler **26**, which constitutes the feet of the figurine, has been moved up to a concealed position. *Id.* at col. 4, ll. 40–59.

Claims 1–4 and 7–14 of the '504 patent are at issue in this appeal. They are directed to transformable toys with certain characteristics. Independent claim 1, which is illustrative, reads in full as follows:

1. A toy comprising:
  - a first movable member;
  - a second movable member positioned adjacent to said first movable member, said second movable member being hingedly connected to said first movable member, wherein the first movable member and the second movable member are moved away from each other to an open position or towards each other to a closed position;
  - a display member connected to a surface of at least one of the first and second movable members, wherein the display member is revealed when the first and second movable members are in the open position, wherein said display member includes a plurality of revealers rotatably connected to at least one of the first and second movable members.

The other challenged claims recite similar variations of transformable toys.

## B

Spin Master is a Canadian-based toy and entertainment company. In 2007, it launched Bakugan, a popular series of transforming robot toys that were sold throughout the world. Complaint at 3, *Spin Master Ltd. v. Mattel, Inc.*, No. 2:18-cv-3435 (C.D. Cal. Apr. 24, 2018). The Bakugan line of toys was launched in conjunction with an animated television series. *Id.*

In 2015, Spin Master sent a letter to SonoKong Co., Ltd., alleging that the manufacture and sale of the “Turning Mecard” line of transforming toys infringed several of Spin Master’s patents, including the '504 patent at issue in

this appeal. SonoKong is a Korean-based company that distributes Turning Mecard toys in Korea and elsewhere. Choirock manufactures the Turning Mecard toys—model cars that transform into animal or humanoid figurines—among other lines of toys.

In 2018, Spin Master sued Mattel, Inc., for selling Turning Mecard toys in the United States. Pursuant to a license agreement with Choirock, Mattel distributed and sold Turning Mecard products in the United States between March 2018 and May 2019.

In the 2018 lawsuit, Spin Master accused Mattel of trying to capitalize on Spin Master's success and alleged that the Turning Mecard toys infringed several of Spin Master's transformable toy patents. Amended Complaint at 4, 35–38, *Spin Master Ltd. v. Mattel, Inc.*, No. 2:18-cv-3435 (C.D. Cal. May 22, 2018). The '504 patent was not one of the patents asserted against Mattel in the complaint.

### C

In 2016, Choirock petitioned for *inter partes* review of all the claims of the '504 patent, alleging several grounds of unpatentability. Three of the prior art references that Choirock relied on in its petition are relevant to the present appeal. The first is an English translation of Japanese Patent Publication No. S60–128693 to Maruyama (“Maruyama '693”). Maruyama '693 discloses what it refers to as a “shape-changing toy.” The toy consists of a figure, such as a figurine of an animal or a robot, which can be hidden when the toy is in the closed position, as illustrated by Figures 1 and 2 from the Japanese patent publication:

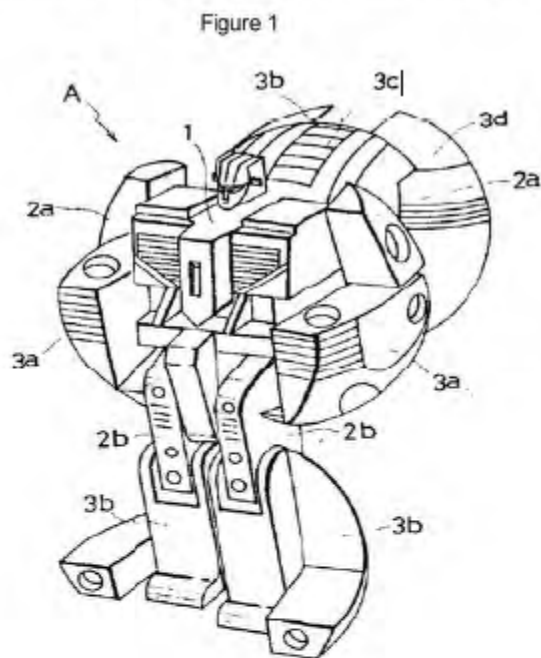
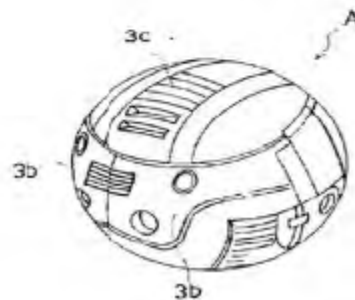

Figure 2



The second prior art reference is U.S. Design Patent No. 287,258 to Maruyama (“Maruyama ’258”). Maruyama ’258 also discloses figures illustrating a toy robot that can be reconfigured into a ball. Although Maruyama ’258 is a different prior art reference from Maruyama ’693, the toy robot depicted in Figure 1 of Maruyama ’693 looks similar to the toy robot in Figure 7 of Maruyama ’258, and the closed view of the toy depicted in Figure 2 of Maruyama

8 CHOIROCK CONTENTS FACTORY CO. v. SPIN MASTER, LTD.

'693 looks generally similar to the closed view of the toy in Figure 13 of Maruyama '258. The third prior art reference is U.S. Patent No. 4,516,948 to Obara. The Obara patent discloses a toy robot that can be reconfigured into a tractor-trailer truck.

The Board found that Maruyama '693 anticipated claims 5 and 6 of the '504 patent. It therefore held claims 5 and 6 to be unpatentable. However, the Board found that Choirock had not proved by a preponderance of the evidence that the remaining claims of the '504 patent were unpatentable on any challenged ground. Choirock appealed.

## II

Appellees Spin Master and inventor Aldric Saucier (collectively, "Spin Master") first challenge Choirock's standing to appeal the Board's final written decision. Because Spin Master's standing challenge implicates our jurisdiction, we begin with the standing issue.

## A

Spin Master contends that Choirock lacks standing to appeal from the Board's decision because Choirock has not suffered an injury attributable to the '504 patent. In particular, Spin Master contends that there is no evidence that Spin Master is likely to assert the '504 patent against Choirock's Turning Mecard line of toys, because Spin Master has not done so in the past. Spin Master also contends that there is no evidence that Choirock is selling the Turning Mecard toys in the United States. For those reasons, Spin Master asserts that any purported injury to Choirock is conjectural or hypothetical at best and is not sufficiently concrete to give Choirock Article III standing to contest the validity of the '504 patent in this court.

We have jurisdiction to review decisions of the Board under 28 U.S.C. § 1295(a)(4)(A). But as an Article III court, we are empowered to adjudicate only cases and



controversies “appropriately resolved through the judicial process.” *Lujan v. Defenders of Wildlife*, 504 U.S. 555, 560 (1992); *E.I. DuPont de Nemours & Co. v. Synvina C.V.*, 904 F.3d 996, 1004 (Fed. Cir. 2018). To establish a case or controversy, an appellant must meet “the irreducible constitutional minimum of standing,” *Lujan*, 504 U.S. at 560. That standing requirement must be satisfied before this court may review an agency’s decision, even when standing is not a prerequisite for obtaining an adjudication of rights before the administrative agency whose decision is subject to our review. See *Synvina*, 904 F.3d at 1004; *Consumer Watchdog v. Wis. Alumni Research Found.*, 753 F.3d 1258, 1261 (Fed. Cir. 2014).

In order to have standing to prosecute a claim in this court, an appellant must have “(1) suffered an injury in fact, (2) that is fairly traceable to the challenged conduct of the defendant, and (3) that is likely to be redressed by a favorable judicial decision.” *Spokeo, Inc. v. Robins*, 136 S. Ct. 1540, 1547 (2016). “That said, where Congress has accorded a procedural right to a litigant, such as the right to appeal an administrative decision, certain requirements of standing—namely immediacy and redressability, as well as prudential aspects that are not part of Article III—may be relaxed.” *Consumer Watchdog*, 753 F.3d at 1261 (citing *Massachusetts v. E.P.A.*, 549 U.S. 497, 517–18 (2007)). Nonetheless, a “party invoking federal jurisdiction must have ‘a personal stake in the outcome’” in order to meet the injury-in-fact requirement. *Consumer Watchdog*, 753 F.3d at 1261 (quoting *City of Los Angeles v. Lyons*, 461 U.S. 95, 101 (1983)).

We reject Spin Master’s contention that Choirock lacks Article III standing to prosecute this appeal. Although Spin Master contends that there is no evidence that Choirock has suffered any injury in fact, the record indicates otherwise. In its 2015 letter to SonoKong, Spin Master stated that “activities including making, using, offering for sale and selling the [Turning] Mecard line of

transforming toys in the United States, Europe and China constitute an infringement of several patents,” including the ’504 patent at issue in this case. Choirock has provided evidence establishing that it has concrete plans to begin selling that product line in the United States by early 2020.

These facts demonstrate that Choirock, a competitor of patent owner Spin Master, has engaged in or likely will engage in activity that would give rise to a possible infringement suit. *See Synvina*, 904 F.3d at 1005; *JTEKT Corp. v. GKN Auto. LTD.*, 898 F.3d 1217, 1220 (Fed. Cir. 2018). Moreover, Spin Master has refused to grant Choirock a covenant not to sue on the ’504 patent, further confirming that Choirock’s risk of liability is not conjectural or hypothetical. *Synvina*, 904 F.3d at 1005. Choirock has thus satisfied the injury-in-fact requirement. There is no dispute that the risk of infringement liability is attributable to Spin Master’s ’504 patent, and it is clear that the risk of liability could be redressed by our review. We therefore conclude that Choirock has Article III standing to prosecute this appeal.

## B

On the merits, the Board first found that Choirock did not satisfy its burden to show that Maruyama ’693 anticipates claims 1–4 of the ’504 patent. In particular, the Board rejected Choirock’s argument that Maruyama ’693 discloses a display member that “includes a plurality of revealers rotatably connected to at least one of the first and second movable members,” as required by claims 1–4 of the ’504 patent. The Board’s finding on that issue is supported by substantial evidence.

Maruyama ’693 identifies the body section of the robot as the first structural element. That element includes the upper section of the robot’s body (1a) and the robot’s head (1b). The second structural element consists of the upper arm sections of the robot (2a), the thigh sections of the legs (2b), and the rear surface section of the shouldering

component (2c), which is not depicted in Figure 1. The patent explains that structural elements 2a, 2b, and 2c are connected to structural element 1. The third structural element, which is rotatably connected to the second structural element, consists of the lower arm sections of the robot (3a), the lower thigh sections of the legs (3b), the front surface of the shouldering components (3c), and the side sections (3d).

In its petition and reply, Choirock argued that the body section of the robot in Maruyama '693—structural element 1—corresponds to the “first movable member” claimed in the '504 patent, and that the leg portions 3a correspond to the claimed “second movable member.” However, Choirock also identified structural element 1 in Maruyama '693 as the “display member” claimed in the '504 patent. Choirock’s petition also appears to take the position that the robot’s body section (1a), head section (1b), upper arm sections (2a), thigh sections (2b), rear surface of the shouldering component (2c), lower arm sections (3a), lower thigh sections (3b), front surface of the shouldering component (3c), and side sections (3d) all correspond to the claimed “plurality of revealers.”

At his deposition, Choirock’s expert confirmed that the feature in Maruyama '693 allegedly corresponding to the claimed “display member” is the robot’s torso. The expert circled that feature and labeled it “A” on Figure 1 from Maruyama '693, as shown in the following exhibit from the expert’s deposition:

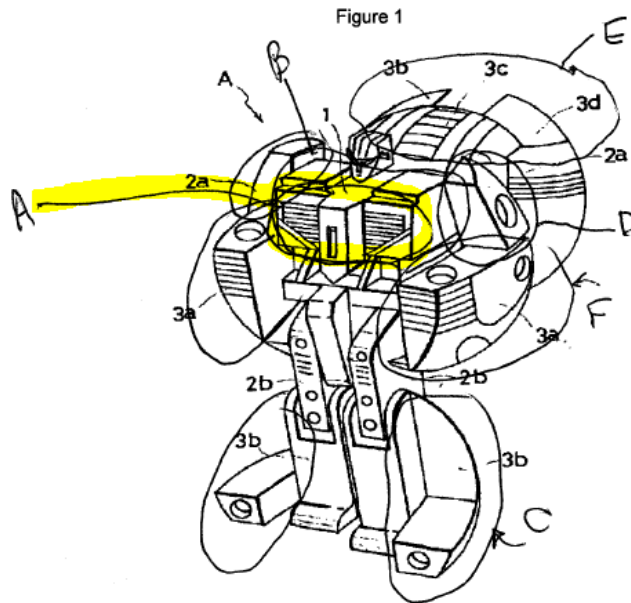

Exhibit 2003 at Figure 1, *Choirock Contents Factory Co., Ltd. v. Spin Master, Ltd.*, No. IPR2017-00030 (P.T.A.B. Sep. 22, 2017) (highlighting added).

The Board found that Choirock failed to show that any of the features from Maruyama '693 that Choirock characterized as “revealers,” other than the robot’s head, form a part of the feature Choirock identified as the “display member.” The Board therefore found that Choirock failed to show that the “display member includes a plurality of revealers,” as required by claims 1–4.

Choirock argues that the Board improperly focused on whether the robot arms in Maruyama '693 “form any part of structural element 1.” According to Choirock, the claim limitation reciting that the “display member includes a plurality of revealers” claim limitation does not require that “revealers” form a part of the “display member.” Choirock contends that the display member of Maruyama '693 should be deemed to “include” a plurality of revealers, because the arms are connected to the display member, i.e., the robot body. The Board properly concluded that the

CHOIROCK CONTENTS FACTORY CO. v. SPIN MASTER, LTD. 13

“includes” requirement in claim 1 is not satisfied by a showing that the arms of the Maruyama ’693 robot are connected to, but are not a part of the display member, i.e., structural element 1, or the robot body.

The ’504 specification and the challenged claims are unambiguous in requiring that the revealers be a part of the display member. The specification describes the entire figurine 13 depicted in Figure 1 as the display member. It then goes on to explain that the figurine 13 includes several constituent parts, such as the head 16 and arms 24, which constitute “revealers.” ’504 patent, col. 3, ll. 21–30.

Choirock has not argued that entire robot figurine in Maruyama ’693 (i.e., the head, body, arms, etc.) constitutes the display member. Instead, Choirock has argued, both before the Board and in this court, that a single constituent part of the overall figure—structural element 1—is the display member. Structural element 1 does not include the robot arms in Maruyama ’693 (or any other alleged revealers other than the robot’s head), so the Board appropriately found that Choirock failed to prove that Maruyama ’693 discloses the “said display member includes a plurality of revealers” claim limitation.

Thus, even if the arms of the robot in Maruyama ’693 are assumed to be rotatably connected to structural element 1, claims 1–4 require that the revealers be “included” in the display member, not simply “connected to” the display member. Choirock failed to show that was the case for the toy that is disclosed in Maruyama ’693. Based on the evidence and argument presented to the Board, we see no reason to disturb the Board’s findings on that issue.

### C

Choirock next contends that the Board erred by finding that Choirock failed to prove that Maruyama ’693 disclosed the following limitation from claims 7 and 8: “wherein the revealing means reveals at least one image when the first

14 CHOIROCK CONTENTS FACTORY CO. v. SPIN MASTER, LTD.

and second movable members are in the open position.” We sustain the Board’s finding, which is supported by substantial evidence.

In its petition, Choirock addressed this limitation by cross-referencing its argument regarding a limitation of claim 5 that it referred to as claim 5d. Choirock’s claim 5d argument consisted of a short discussion and another cross-reference to what Choirock referred to as claim 1c. The Board denied institution of claims 7 and 8 because it found that none of those portions of the petition even mentioned the claimed requirement of an “image,” let alone explained how that requirement was met.

The Board later modified its decision in light of *SAS Institute, Inc. v. Iancu*, 138 S. Ct. 1348 (2018), to include all the challenged claims and all the grounds presented in the petition. Choirock used that occasion to attempt to explain how it had addressed the disputed limitation.

Choirock said that its mapping of claim 5d indicated that surfaces of the robot in Maruyama ’693 are revealed when the arms are moved. Choirock further argued that while it had not expressly stated that the Maruyama robot’s arms include images, it is clear from other, unreferenced portions of the petition that those components include images. In particular, Choirock referred to its argument relating to claim 2, that “upper and lower sections 2a, 3a have the image of shoulders and arms; and legs 3b have the image of legs and feet.”

In its final written decision, the Board found that Choirock had not adequately addressed the disputed limitation. The Board stated that “[i]n general, contrary to Petitioner’s suggestion, we do not glean from a mere suggestion of robot body parts constituting ‘revealers’ that they also constitute or include an image or images.” The Board also rejected Choirock’s incorporation of its claim 2 argument because the petition did not cross-reference the

CHOIROCK CONTENTS FACTORY CO. v. SPIN MASTER, LTD. 15

claim 2 argument, even though it cross-referenced other portions of the petition.

The Board then ruled that even accepting Choirock's argument that its presentation as to claim 2 should be deemed applicable to claims 7 and 8, the petition still failed to demonstrate that Maruyama '693 anticipated those claims. The Board construed the "revealing means" limitation of claims 7 and 8 to require that the revealer "at some point be moved to expose to viewing a portion thereof that previously was not exposed," a construction that Choirock does not challenge on appeal. The Board further noted that Choirock's discussion of claim 2 addressed the limitation providing that "the revealers each include at least one surface having an image formed thereon." Choirock argued that the upper and lower arms in Maruyama '693 "have the image of shoulders and arms" and the legs "have the image of legs and feet." The Board found that the argument as to that claim was directed to whether those components "have" images, but failed to address the limitation of claims 7 and 8 requiring that the revealers move to expose previously unexposed images.

We see no reason to disturb the Board's findings. Setting aside the flaws in the manner in which Choirock presented its arguments to the Board, substantial evidence supports the Board's finding that Choirock did not prove anticipation. As the Board found, even accepting that the arms contain images, as Choirock asserts, Choirock did not demonstrate that the surface that is exposed when the components are moved contains an image that was previously unexposed.

Finally, we reject Choirock's argument that the Board was required to find claim 7 to be anticipated because it found that claim 6 was anticipated. As the Board noted, different claims have different requirements, and those differences matter. For example, claim 6 requires that the revealers include at least one surface having an image

formed thereon, not that the surface having that image must be revealed when the first and second movable members are in the open position, as required by claim 7.

D

Choirock next argues that the Board erred by finding that Choirock failed to prove that Maruyama '258, in view of Obara, rendered claims 1–4 and 7–8 invalid for obviousness.

1. With respect to claims 1–4, Choirock again focuses on the limitation that “said display member includes a plurality of revealers.” In particular, Choirock contends that the Board erroneously found that Choirock did not clearly identify where Maruyama '258 teaches that limitation. We disagree.

In addressing a different limitation, Choirock provided the following annotated illustration in its petition:

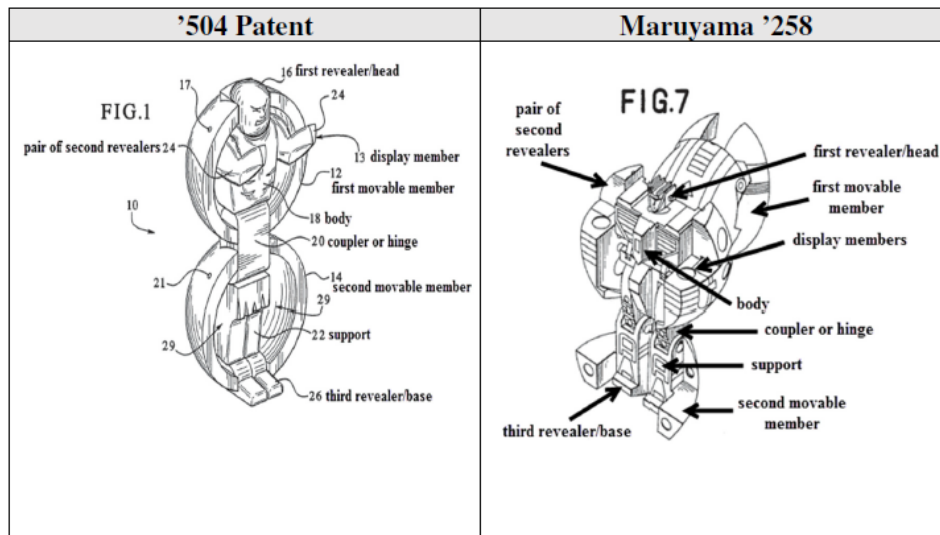

Appellant’s Br. at 58. Choirock added the annotations on the right to Figure 7 of Maruyama '258, including the words “display members.” In its reply, Choirock argued to the Board that it was clear from the side-by-side



comparison that Choirock was identifying the entire figurine in Maruyama '258 as the display member. The Board rejected that argument.

First, the Board noted that the annotation in question referred to plural “display members.” That, along with the placement of the arrow, as the Board noted, would seem to indicate that Choirock was contending that the two arms, not the overall figurine, were the display members.<sup>1</sup>

Second, as he had with Maruyama '693, Choirock's expert circled the front of the Maruyama '258 robot's torso and labeled it “A” when he was asked to identify the display member in Figure 7 of Maruyama '258:

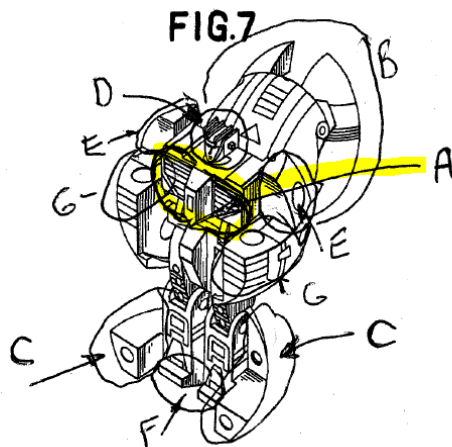

Exhibit 2002 at Figure 7, *Choirock Contents Factory Co., Ltd. v. Spin Master, Ltd.*, No. IPR2017-00030 (P.T.A.B.)

---

<sup>1</sup> Choirock contends that because the petition separately identifies the robot arms as revealers, not display members, the Board's statement was unfounded. We disagree. The patent clearly refers to a “display member” that is made up of constituent parts, some of which are revealers. It was therefore not improper for the Board to interpret the petition as arguing that the arms were both revealers and display members.

18 CHOIROCK CONTENTS FACTORY CO. v. SPIN MASTER, LTD.

Sep. 22, 2017) (highlighting added). As the Board noted, the expert's testimony undercuts Choirock's contention that the petition identified the entire figurine in Maruyama '258 as the display member.<sup>2</sup>

In light of those representations, there is no force to Choirock's contention that the Board erred in finding that Choirock failed to clearly identify where Maruyama '258 taught the "display member" limitation.<sup>3</sup> Accordingly, we reject Choirock's obviousness argument as to claims 1–4.

2. With respect to the issue of obviousness as to claims 7 and 8, Choirock focuses on the following limitation: "wherein the revealing means reveals at least one image when the first and second movable members are in the open position."

The Board found that Choirock failed to provide sufficient evidence or reasoning that the head of the toy robot in Maruyama '258 moved or could be made to move to expose the image of a face that was not previously exposed. Choirock contends the Board's finding should be reversed

---

<sup>2</sup> Choirock also contends that the Board erred in relying on testimony regarding the Maruyama '693 reference as opposed to the Maruyama '258 reference. In the portion of the Board's opinion to which Choirock refers, the Board merely summarized the patent owner's arguments. The Board did not base its analysis on testimony relating to the Maruyama '693 reference.

<sup>3</sup> Choirock's statement earlier in its petition that Maruyama '258 reveals a display member "in the same manner as the '504 patent" does not add the needed clarity. In addition to being directed to a separate claim element, that statement does not explain what portions of the toy constitute the display member; instead, it addresses how the toy is opened from a closed position to reveal a display member.

CHOIROCK CONTENTS FACTORY CO. v. SPIN MASTER, LTD. 19

because the Board ignored portions of the petition contending that it would have been obvious to modify Maruyama '258 in light of Obara to make the robot's head rotatable so as to expose the face if it was not previously exposed.

The problem with Choirock's argument is that the portions of the petition Choirock relies on are directed to claim 1 of the '504 patent, not claim 7. Choirock has not rebutted the Board's finding that the petition did not argue that it would have been obvious to modify Maruyama '258 to meet the requirements of claim 7.

In its petition, Choirock asserted generally that claims 1–11 and 13–14 were unpatentable as obvious in view of Maruyama '258 and further in view of Obara. In order to show that certain limitations in those claims were met, Choirock argued that it would have been obvious to substitute movable or rotatable toy parts taught in Obara to the extent that the Board found Maruyama '258 disclosed fixed toy parts and thus did not satisfy those limitations. For example, in arguing that claim 9 was obvious, Choirock said that “it would have been obvious . . . to modify Maruyama '258 to include a movably attached head as taught in Obara[.]”

Despite specifically arguing that the Board should substitute the movable toy parts of Obara for those in Maruyama '258 to establish the obviousness of other claims, Choirock never suggested in its petition that the movable parts of Obara should be substituted to satisfy the disputed limitation in claims 7 and 8. Although Choirock contended in its reply brief to the Board that “it would have been obvious . . . to add rotatability to the head, arms[,] and feet” of the figurine in Maruyama '258 in light of Obara, the Board reasonably rejected Choirock's contention as a new argument that was not presented in Choirock's petition. In its briefs to this court, Choirock has not challenged the Board's ruling on that issue, and it has not relied on arguments made in its reply brief to the Board. We

therefore sustain the Board's finding that Choirock failed to prove that Maruyama '258 disclosed the disputed limitation in claims 7 and 8.

### E

Finally, Choirock contends that the Board erroneously found that Choirock failed to show that Maruyama '258 and Obara teach or suggest "a coupler positioned between the first and second movable members, said first movable member being movably connected to one end of the coupler and said second movable member being movably connected to an opposite end of the coupler," as required by claim 9 and its dependent claims.

Choirock's argument in its petition regarding that limitation consisted of two sentences and an accompanying annotated figure:

As shown below, Maruyama '258 Figure 2 shows a coupler between the first and second movable members. The coupler movably connects the first and second movable members so that they may move into open and closed positions in the same manner as the '504 patent.

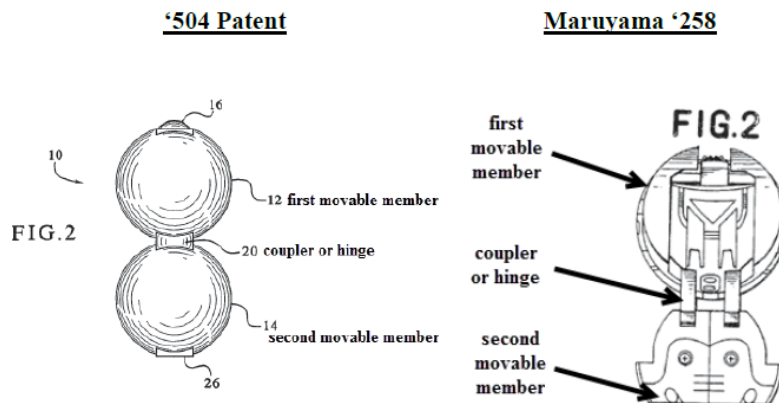

That brief statement, along with the pair of figures, was repeated verbatim in Choirock's expert declaration

CHOIROCK CONTENTS FACTORY CO. v. SPIN MASTER, LTD. 21

without further elaboration. The Board found that Choirock's conclusory assertion did not persuasively address the specific language of the claim.

As the Board found, simply asserting that the coupler between the two movable members in Maruyama '258 "movably connects the first and second movable members so that they may move into open and closed positions in the same manner" as in the '504 patent was not sufficient to satisfy Choirock's burden to show that Maruyama '258 taught the limitation requiring that the second movable member be "movably connected to an opposite end of the coupler."

In discussing the disputed limitation, Choirock did not address, either in its petition or its reply, whether the alleged second movable member was on the "opposite end of the coupler." Nor did Choirock address how the two components shown in Maruyama '258 as extending between the first and second movable members constitute a single "coupler," as recited in claim 9 of the '504 patent. And while the evidence may be sufficient to show that the alleged coupler or hinge mechanism in Maruyama '258 facilitates the relative movement of the first and second movable members between the open and closed positions, Choirock introduced no evidence that the coupler or couplers were "movably connected" to both movable members, as opposed to, for example, being movably connected to one of the members and rigidly fixed to the other.

We therefore conclude that the Board's factual findings are supported by substantial evidence and that Choirock failed to establish that claim 9 and its dependent claims would have been obvious in light of Maruyama '258 and Obara.

**AFFIRMED**

NOTE: This disposition is nonprecedential.

**United States Court of Appeals  
for the Federal Circuit**

---

**CHOIROCK CONTENTS FACTORY CO., LTD.,**  
*Appellant*

v.

**ALDRIC SAUCIER, SPIN MASTER, LTD.,**  
*Appellees*

---

2019-1335

---

Appeal from the United States Patent and Trademark Office, Patent Trial and Appeal Board in No. IPR2017-00030.

---

DYK, *Circuit Judge*, dissenting in part.

The '504 patent is directed to a transformable toy shaped like a ball that can open to reveal a figurine. The prior art references—Maruyama '693 and Maruyama '258—disclose a nearly identical toy that can open to reveal a robot figurine. While the Board may have been correct in finding that Choirock did not establish that claims 1–4 and 7–8 were anticipated, I think the Board demonstrably erred in holding that Choirock failed to show that claims 1–4 and 7–8 would have been obvious. I respectfully dissent from the majority's decision to affirm the Board with respect to those grounds. I join the majority opinion as to standing and claim 9 and its dependent claims.

## I

## OBVIOUSNESS OF CLAIMS 1–4

Claims 1–4 recite “wherein said display member includes a plurality of revealers.” The ’504 patent describes that the “display member . . . is a figure or figurine.” ’504 patent at col. 3, ll. 21–22. The Board and majority agree that “display member” refers to the entire figurine in the ’504 patent. This limitation is clearly disclosed in the prior art. Maruyama ’258’s robot toy shows a figurine with a head, arms, and feet just like the one in the ’504 patent, and thus discloses the recited “display member.” Not surprisingly, in the obviousness analysis, the Board never found that Maruyama ’258 fails to disclose the “display member.”

Instead, the Board held that Choirock did not “provide[] a clear, consistent identification of which parts of Maruyama ’258’s toy . . . constitute a ‘display member.’” J.A. 31. The panel majority agrees, reasoning that the arrow in Choirock’s annotation of Figure 7 in Maruyama ’258 seemed to indicate that the robot toy’s “two arms, not the overall figurine, were the display members,” that the annotation referred to plural “display members,” and that Choirock’s expert testimony circled the robot’s torso when asked to identify the display member. Maj. Op. 17–18.

Choirock’s annotation of Figure 7 of Maruyama ’258, however, simply identified the overall figurine as the display member in the same way as Figure 1 of the ’504 patent, which also points an arrow to the arms when identifying the figurine as the “display member.” Significantly, in the annotation of Figure 10 of Maruyama ’258 on the same page in the Petition, the arms were labeled as “revealer” and not “display members.” The inadvertent use of the plural “display members” in the annotation of Figure 7 was clarified in the Reply, which explicitly identified the figurine as the display member. Specifically, after re-

CHOIROCK CONTENTS FACTORY CO. v. SPIN MASTER, LTD. 3

ceiving Spin Master's Response, Choirock in its Reply confirmed that "like Figure 1 of the [']504 patent, annotated Figure 7 [of Maruyama '258] identifies the figurine as the display member." J.A. 506. Choirock further made clear that "the display member in Maruyama-258 is the figurine." *Id.* These reply arguments simply elaborated the previous argument. "Parties are not barred from elaborating on their arguments on issues previously raised." *Chamberlain Grp., Inc. v. One World Techs., Inc.*, 944 F.3d 919, 925 (Fed. Cir. 2019).

The expert's testimony is of no significance here. He labeled the torso of Maruyama '258's robot toy as the "display member" using a different definition of "display member." Maruyama '258 plainly shows a "display member" under the Board's construction.

Due to the above error, the Board did not address Spin Master's other arguments why the prior art would not have rendered claims 1–4 obvious in light of other limitations in those claims. I therefore would remand for further proceedings.

## II

### OBVIOUSNESS OF CLAIMS 7 AND 8

Claims 7 and 8 recite "wherein the revealing means reveals at least one image." Choirock argues that this limitation is disclosed in a combination of Maruyama '258 and Obara. Regarding this limitation, the Board stated that Choirock "did not argue that it would have been . . . obvious to modify Maruyama '258's head, arms, or feet to rotate" in light of Obara and that Choirock thus failed to show obviousness of those claims. J.A. 37. The majority affirms the Board's finding. But, in fact, Choirock did assert in its Petition that "it would have been simple and obvious . . . to combine [those two references]" under the general section covering claims 7 and 8: "Ground 3: Claims 1–11, 13–14 are unpatentable under 35 U.S.C. §103 as being obvious in



view of Maruyama [']258 and further in view of Obara.” J.A. 210. And, in Choirock’s Reply in response to the rotatability issue raised by Spin Master, Choirock argued that it “would have been obvious to . . . add rotatability to the head, arms[,] and feet” of the figurine in Maruyama ’258 in light of Obara “so as to reveal a previously unseen image.” J.A. 514. This response was proper. *Chamberlain*, 944 F.3d at 925. The Board erred by ignoring Choirock’s arguments.

Under the asserted modification, Maruyama ’258’s robot would have a rotatable head and feet that expose images (face and feet) when rotated and thus “reveal[] at least one image” as required by claims 7 and 8. Indeed, during oral argument, Spin Master did not deny that the modification would satisfy the disputed limitation. Oral Arg. 26:51–27:12, available at <http://oralarguments.cafc.uscourts.gov/default.aspx?fl=2019-1335.mp3>.

Due to the above error, the Board did not address Spin Master’s other reasons why the prior art would not have rendered claims 7 and 8 obvious. I therefore would remand for further proceedings.