



USPTO Guidelines for Determining Obviousness in View of the Supreme Court Decision in *KSR International Co. v. Teleflex Inc.*

**TC 1600 Biotech/Chem/Pharma Customer Partnership Meeting
USPTO, Alexandria, VA
December 4, 2007**

**Kathleen Kahler Fonda, Legal Advisor
USPTO Office of Patent Legal Administration**



§ 103 Examination Guidelines

Published in the Federal Register

- On October 10, 2007**
- At 72 FR 57526**



§ 103 Examination Guidelines

- These guidelines do not constitute substantive rule making.**
- They are not intended to create any right or benefit, substantive or procedural, enforceable by any party against the Office.**
- Any failure by Office personnel to follow these guidelines is neither appealable nor petitionable.**



Outline

- **the *KSR* decision : *KSR Int'l Co. v. Teleflex Inc.*, 550 U.S. —, 82 USPQ2d 1385 (2007)**
- **determining obviousness under 35 U.S.C. § 103**
- **rebutting a rejection under 35 U.S.C. § 103**



***KSR* Background**

- **Technology**
- **Procedural History**

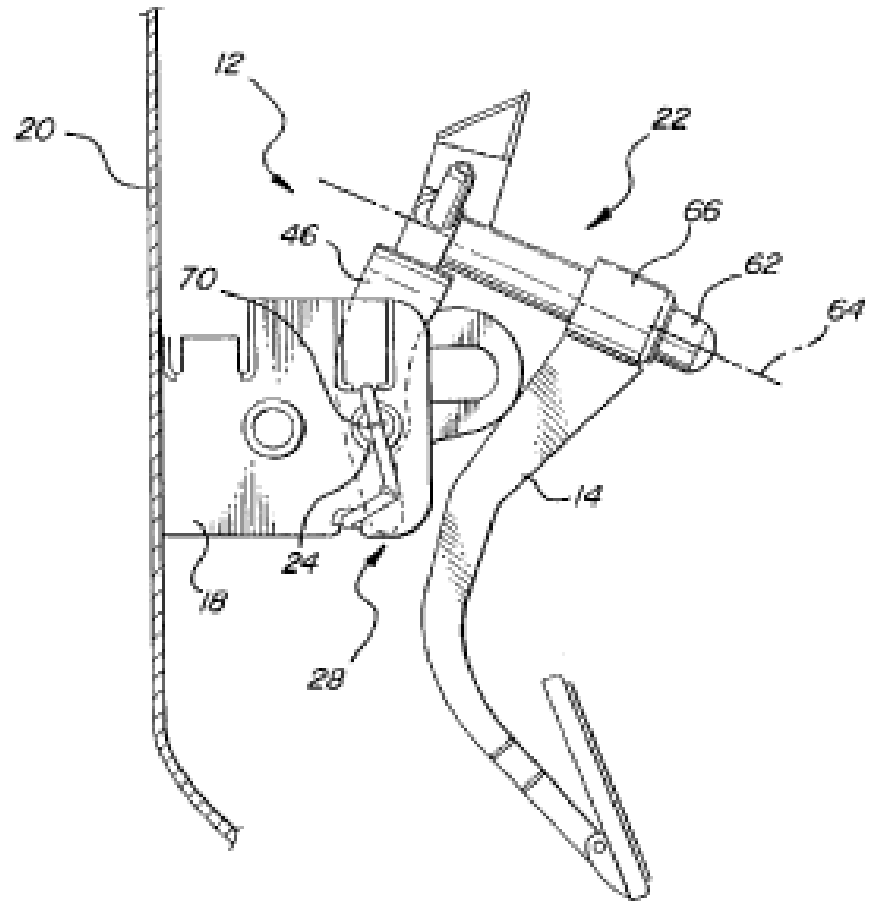



***KSR* Reaffirms the *Graham* Analysis for Obviousness**

"In *Graham* [], the Court set out a framework for applying the statutory language of § 103, . . . [T]he factors continue to define the inquiry that controls. If a court, or patent examiner, conducts this analysis and concludes the claimed subject matter was obvious, the claim is invalid under § 103." *KSR* at 1391.



Federal Circuit's Four Errors

The Supreme Court stated that the Federal Circuit erred when it applied the well-known teaching-suggestion-motivation (TSM) test in an overly rigid and formalistic way.

***KSR* at 1396-97.**



Federal Circuit's Four Errors (*KSR*, 82 USPQ2d at 1397)

- (1) "[H]olding that courts and patent examiners should look only to the problem the patentee was trying to solve."**
- (2) Assuming "that a person of ordinary skill attempting to solve a problem will be led only to those elements of prior art designed to solve the same problem."**



Federal Circuit's Four Errors (*KSR*, 82 USPQ2d at 1397)

- (3) Concluding "that a patent claim cannot be proved obvious merely by showing that the combination of elements was 'obvious to try.' "**
- (4) Overemphasizing "the risk of courts and patent examiners falling prey to hindsight bias" and as a result applying "[r]igid preventative rules that deny factfinders recourse to common sense."**



TSM Remains a Valid Approach to the *Graham* Inquiries under *KSR*

"When it first established the requirement of demonstrating a teaching, suggestion, or motivation to combine known elements in order to show that the combination is obvious, the Court of Customs and Patent Appeals captured a helpful insight. . . . There is no necessary inconsistency between the idea underlying the TSM test and the *Graham* analysis."

***KSR* at 1396.**



Examiner's Approach to § 103 in Light of *KSR*

- **The basic approach to determining obviousness remains the same.**
- ***KSR* provides a more expansive view of prior art.**
- ***KSR* emphasizes that any reasoned argument grounded in the *Graham* inquiries may form the basis for a holding of obviousness.**



The Basic Approach to Determining Obviousness Remains the Same

An examiner is still required to provide a reasoned statement of rejection grounded in the *Graham* inquiries. He or she must articulate a reason or rationale to support the obviousness rejection.

See *KSR* at 1396 ("To facilitate review, [the obviousness] analysis should be made explicit.") (citing *In re Kahn*, 441 F.3d 977, 988 (Fed. Cir. 2006)).



The Basic Approach to Determining Obviousness Remains the Same

An invention that merely combines known prior art elements using known techniques to produce predictable results is likely to be unpatentable.

**"[W]hen a patent claims a structure already known in the prior art that is altered by the mere substitution of one element for another known in the field, the combination must do more than yield a predictable result. . . . [W]hen the prior art teaches away from combining certain known elements, discovery of a successful means of combining them is more likely to be nonobvious."
KSR at 1395, citing *United States v. Adams*, 383 U.S. 39, 50-52.**



***KSR* Provides a More Expansive View of Prior Art**

"The obviousness analysis cannot be confined . . . by overemphasis on the importance of published articles and the explicit content of issued patents. . . ."



***KSR* Provides a More Expansive View of Prior Art**

... In many fields it may be that there is little discussion of obvious techniques or combinations, and it often may be the case that market demand, rather than scientific literature, will drive design trends."

***KSR* at 1396.**



Any Reasoned Argument Grounded in *Graham* May Form the Basis for a *Prima Facie* Case of Obviousness

"If a court, or patent examiner, conducts [the *Graham*] analysis and concludes the claimed subject matter was obvious, the claim is invalid under § 103."

***KSR* at 1391.**

"The obviousness analysis cannot be confined by a formalistic conception of the words teaching, suggestion, and motivation, or by overemphasis on the importance of published articles and the explicit content of issued patents."

***KSR* at 1396.**



Any Reasoned Argument Grounded in *Graham* May Form the Basis for a *Prima Facie* Case of Obviousness

- **The TSM test is just one of a number of valid rationales that may be employed when determining obviousness under 35 U.S.C. § 103.**
- **The inapplicability of the TSM test does not necessarily result in a conclusion of non-obviousness.**



The Examiner as Fact Finder

- **Examiners act as fact finders when resolving the *Graham* inquiries.**
- **Examiners must articulate findings as to the scope and content of the prior art, as necessary, to support the obviousness rejection being made.**



The Examiner as Fact Finder

In formulating a rejection under 35 U.S.C. § 103, the examiner should focus on the state of the art and **not impermissible hindsight**, e.g. applicant's disclosure.

See *KSR* at 1397 ("A factfinder should be aware, of course, of the distortion caused by hindsight bias and must be cautious of arguments reliant upon *ex post* reasoning.") (citing *Graham*, 383 U.S. at 36).



Key Points

Examiners need to account for all claim limitations in their rejections, either by indicating how each limitation is shown by the reference(s) applied, or by providing an explanation.



Key Points

- **Prior art is not limited to the four corners of the documentary prior art being applied.**
 - **Prior art includes both the specialized understanding of one of ordinary skill in the art, and the common understanding of the layman.**
 - **It includes "background knowledge possessed by a person having ordinary skill in the art. . . . [A] court can take account of the inferences and creative steps that a person of ordinary skill in the art would employ." *KSR* at 1396.**
- **Examiners may rely on, for example, official notice, common sense, and design choice.**



Making a *Prima Facie* Case of Obviousness

Examiners must:

- ❑ **Resolve the *Graham* inquiries.**
- ❑ **Articulate appropriate factual findings.**
- ❑ **Explain the reasoning that provides a nexus between the factual findings and the legal conclusion of obviousness.**



Rationales

- **One or more of the rationales set forth in the following slides may be relied upon to support a conclusion of obviousness. **The list of rationales provided herein is not intended to be an all-inclusive list.****
- **The key to supporting any rejection under 35 U.S.C. § 103 is the clear articulation of the reasons why the claimed invention would have been obvious.**



Rationale A. Combining prior art elements according to known methods to yield predictable results.

"The combination of familiar elements according to known methods is likely to be obvious when it does no more than yield predictable results. . . . [W]hen a patent 'simply arranges old elements with each performing the same function it had been known to perform' and yields no more than one would expect from such an arrangement, the combination is obvious."

***KSR* at 1395-66 (citing *Sakraida v. AG Pro, Inc.*, 425 U.S. 273, 282 (1976)).**



Rationale A. Combining prior art elements according to known methods to yield predictable results.

Findings to support obviousness:

- 1) a finding that the prior art included each element claimed although not necessarily in a single reference;**
- 2) a finding that one of ordinary skill in the art could have combined the elements as claimed by known methods and that in combination, each element merely would have performed the same function as it did separately; and**
- 3) a finding that one of ordinary skill in the art would have recognized that the results of the combination were predictable.**



Rationale A. Combining prior art elements according to known methods to yield predictable results.

Reasoning: All the claimed elements were known in the prior art and one skilled in the art could have combined the elements as claimed by known methods with no change in their respective functions, and the combination would have yielded predictable results to one of ordinary skill in the art at the time of the invention.



Rationale B. Simple substitution of one known, equivalent element for another to obtain predictable results

"[W]hen a patent claims a structure already known in the prior art that is altered by the mere substitution of one element for another known in the field, the combination must do more than yield a predictable result."

***KSR* at 1395 (citing *United States v. Adams*, 383 US 39, 50-51 (1966)).**



Rationale B. Simple substitution of one known, equivalent element for another to obtain predictable results

Findings to support obviousness:

- 1) a finding that the prior art contained a device which differed from the claimed device by the substitution of some components with other components;**
- 2) a finding that the substituted components and their functions were known in the art;**
- 3) a finding that one of ordinary skill in the art could have substituted one known element for another and the results of the substitution would have been predictable.**



Rationale B. Simple substitution of one known, equivalent element for another to obtain predictable results

Reasoning: The claim would have been obvious because the substitution of one known element for another would have yielded predictable results to one of ordinary skill in the art at the time of the invention.



Rationale C. Use of known technique to improve similar devices (methods, or products) in the same way.

"[I]f a technique has been used to improve one device, and a person of ordinary skill in the art would recognize that it would improve similar devices in the same way, using the technique is obvious unless its actual application is beyond his or her skill. . . . [A] court must ask whether the improvement is more than the predictable use of prior art elements according to their established functions."

***KSR* at 1396.**



Rationale C. Use of known technique to improve similar devices (methods, or products) in the same way.

Findings to support obviousness:

- 1) a finding that the prior art contained a “base” device upon which the claimed invention is an improvement;**
- 2) a finding that the prior art contained a “comparable” device that was improved in the same way as the claimed invention; and**
- 3) a finding that one of ordinary skill could have applied the known “improvement” technique in the same way to the “base” device and the results would have been predictable.**



Rationale C. Use of known technique to improve similar devices (methods, or products) in the same way.

Reasoning: The claim would have been obvious because the technique for improving a particular class of devices was part of the ordinary capabilities of a person of ordinary skill in the art, in view of the teaching of the technique for improvement in other situations.



Rationale D. Applying a known technique to a known device (method, or product) ready for improvement to yield predictable results.

"[T]he claimed subject matter may involve [] the mere application of a known technique to a piece of prior art ready for the improvement."

***KSR* at 1396.**



Rationale D. Applying a known technique to a known device (method, or product) ready for improvement to yield predictable results.

Findings to support obviousness:

- 1) a finding that the prior art contained a "base" device;**
- 2) a finding that the prior art contained a known technique that is applicable to the base device; and**
- 3) a finding that one of ordinary skill in the art would have recognized that applying the known technique would have yielded predictable results.**



Rationale D. Applying a known technique to a known device (method, or product) ready for improvement to yield predictable results.

Reasoning: The claim would have been obvious because a particular known technique was recognized as part of the ordinary capabilities of one skilled in the art.



Rationale E. "Obvious to try" – choosing from a finite number of predictable solutions.

"When there is a design need or market pressure to solve a problem and there are a finite number of identified, predictable solutions, a person of ordinary skill has good reason to pursue the known options within his or her technical grasp. If this leads to the anticipated success, it is likely the product not of innovation but of ordinary skill and common sense."

***KSR* at 1397.**



Rationale E. "Obvious to try" – choosing from a finite number of predictable solutions.

Findings to support obviousness:

- 1) a finding that there had been a recognized problem or need in the art including a design need or market pressure to solve a problem;**
- 2) a finding that there had been a finite number of identified predictable potential solutions;**
- 3) a finding that one of ordinary skill in the art could have pursued the known potential options with a reasonable expectation of success.**



Rationale E. "Obvious to try" – choosing from a finite number of predictable solutions.

Reasoning: The claim would have been obvious because "a person of ordinary skill has good reason to pursue the known options within his or her technical grasp. If this leads to the anticipated success, it is likely the product not of innovation but of ordinary skill and common sense."



Rationale F. Known work in one field of endeavor may prompt variations of it for use in either the same field or a different one based on design incentives or other market forces if the variations would have been predictable to one of ordinary skill in the art.

"When a work is available in one field of endeavor, design incentives and other market forces can prompt variations of it, either in the same field or a different one. If a person of ordinary skill can implement a predictable variation, § 103 likely bars its patentability."

***KSR* at 1396.**



Rationale F. Known work in one field of endeavor may prompt variations of it for use in either the same field or a different one based on design incentives or other market forces if the variations would have been predictable to one of ordinary skill in the art.

Findings to support obviousness:

- 1) a finding that the scope and content of the prior art, whether in the same or different field of endeavor, included a similar or analogous device.**
- 2) a finding that there were design incentives or market forces which would have prompted adaptation of the known device.**
- 3) a finding that the differences between the claimed invention and the prior art were encompassed in known variations or in a principle known in the prior art.**
- 4) a finding that one of ordinary skill in the art, in view of the design incentives or market forces, could have implemented the claimed variation of the prior art, and the claimed variation would have been predictable.**



Rationale F. Known work in one field of endeavor may prompt variations of it for use in either the same field or a different one based on design incentives or other market forces if the variations would have been predictable to one of ordinary skill in the art.

Reasoning: The claim would have been obvious because the design incentives or market forces provided a reason to make an adaptation, and the invention resulted from application of the prior knowledge in a predictable manner.



Rationale G. TSM Test

Findings to support obviousness:

- 1) **a finding that there was some teaching, suggestion, or motivation, either in the references themselves or in the knowledge generally available to one of ordinary skill in the art, to modify the reference or to combine reference teachings;**
- 2) **a finding that there was reasonable expectation of success.**



Rationale G. TSM Test

Reasoning: The claim would have been obvious because a person of ordinary skill in the art would have been motivated to combine the prior art to achieve the claimed invention and there would have been a reasonable expectation of success.



Applicant's Response

If an applicant traverses an obviousness rejection under § 103, a reasoned statement must be included explaining why the applicant believes the Office has erred substantively as to the factual findings or the conclusion of obviousness. 37 CFR 1.111(b).



Rebuttal Evidence

- ❑ **Applicant may submit evidence, in a timely manner, to rebut a *prima facie* showing of obviousness.**
- ❑ **Rebuttal evidence may include evidence of secondary considerations such as commercial success, long felt but unsolved needs, failure of others, and unexpected results.**
- ❑ **Rebuttal evidence may address the particular findings of fact or line of reasoning provided by the examiner in support of obviousness.**



Rebuttal Evidence

- ❑ **An mere argument that an examiner has not provided an argument based on TSM, or that no motivation is explicitly stated in the applied reference(s), is not sufficient to overcome a *prima facie* case of obviousness.**
- ❑ **If an examiner maintains a rejection under 35 U.S.C. § 103 after receiving applicant's response and reweighing all of the evidence, he or she must clearly explain the reasons for doing so.**



KSR Summary

- **reaffirmed the four-prong analysis for obviousness set forth in *Graham*;**
- **stressed that a reasoned analysis must be provided to support any conclusion of obviousness;**
- **recognized the continued viability of the "teaching, suggestion, or motivation" (TSM) approach when properly applied;**



KSR Summary

- **explained that TSM is not to be employed in a rigid or formalistic manner;**
- **clarified that TSM is not the exclusive test whereby obviousness may be determined; and**
- **explained that a broader range of rationales may be employed to support an obviousness rejection.**



Conclusion

A reasoned explanation supporting a finding of obviousness can be based directly on the *Graham* inquiries without specific application of the TSM approach. Regardless of the approach taken, the Court emphasized the necessity of providing a clearly articulated rationale in order to establish obviousness.



Information

Kathleen Fonda, OPLA Legal Advisor

(571) 272-7754; kathleen.fonda@uspto.gov

**Obviousness examination guidelines
available at:**

<http://www.uspto.gov/web/offices/com/sol/notices/72fr57526.pdf>